



LUSTOR™
LUBRICATION
STORAGE SYSTEMS



The OilSafe® suite of lubrication management products is the reliable choice for safe and efficient storage, transfer and identification to help you establish best practices throughout your workflow. Every step is color-coded to eliminate risk and human error - simplifying maintenance, while extending the life of the equipment that keeps your business running.

THE SCALABLE SOLUTION.

FOR A MODERN LUBE ROOM.



LUSTOR™ LUBRICATION STORAGE SYSTEMS

Best-in-class lubrication programs depend on the methods applied for storing, transferring and applying lubricants to your valuable equipment, and the first step to help ensure clean oil enters your equipment is to filter it to an acceptable level. Luster systems deliver the storage and dispensing benefits you trust, in cost-effective, compact and expandable units. Designed to protect every liter of oil from on-site environmental conditions, Luster systems combine proper storage, filtration and identification to create an efficient and organized workflow. This, in turn, ensures that your lubricants remain dry and contaminant-free before they enter your equipment; saving you time and money.

SYSTEM CONFIGURATIONS

Three different system configurations are offered to fit your application needs and requirements.



**WALL MOUNT
(NO RESERVOIR)**

PART #LST0310
For use with drum or tote



65 GALLON (250 LITER)

PART #LST2310



130 GALLON (500 LITER)

PART #LST5310

WHY TRUST LUSTOR™ SYSTEMS

Ideal for all Plant Maintenance & Lube Rooms

BENEFITS

- Compact and expandable
- Cost-effective
- Organized and clean workspace
- Increases work environment safety
- Prevents cross-contamination
- Improves lubricant quality
- Lowers lubricant and maintenance costs
- Less equipment downtime
- Increases productivity

FEATURES

- Impact resistant poly-tank
 - *Protects lubricants from sunlight and does not rust or react with chemicals in lubricants*
- Heavy-duty pneumatic pump (3:1 air/oil pump)
- 3-way filtration (10-micron filter)
- Oil consumption meter
- Auto shut-off dispensing tap
- Oil level indicator
- Drip tray
- Drum transfer hose kit
- Drum adapter kit (w/part #LST0310)
- Desiccant breather to keep dust and moisture out

OPTIONAL UPGRADES/ADD-ONS:

- Custom Fluid ID Label (for front of system)
- 3 um or 20 um Filter
- Pneumatic 5:1 Pump
- Luster Spill Containment - Part #LSTSCP
- Colorized Quick Connects
- IBC Spill Pallet



HOW LUSTOR™ SYSTEMS WORK

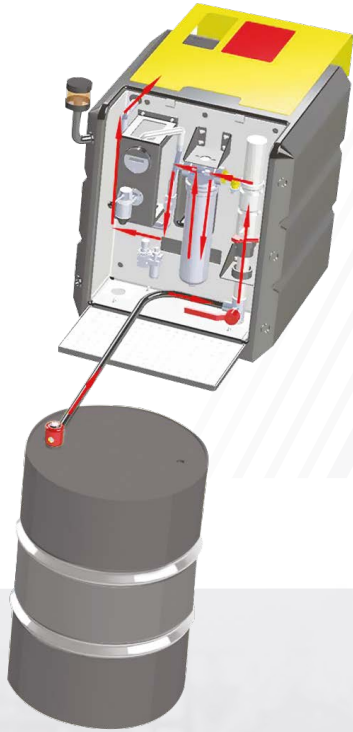

MODE 1

- Transfer oil from Drum to Unit.
- First filter pass while transferring.

MODE 2

- Filtration in circulation on Unit.
- Inline circulation filtration.
- Second filter pass.



MODE 3

- Filtration before dispensing into OilSafe Transfer Container.
- Third filter pass.

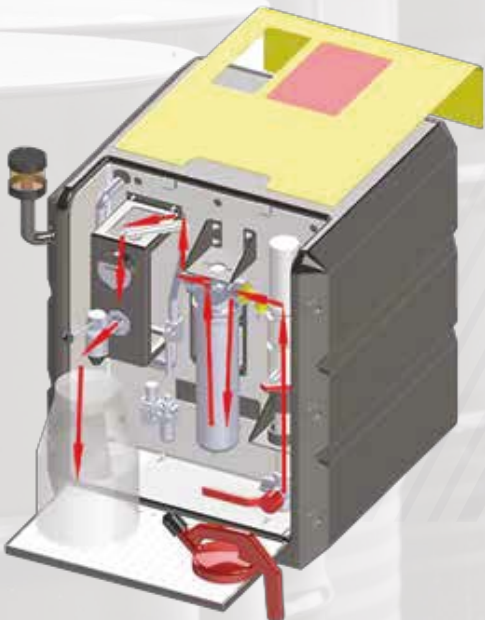

THE LUSTOR™ SYSTEMS

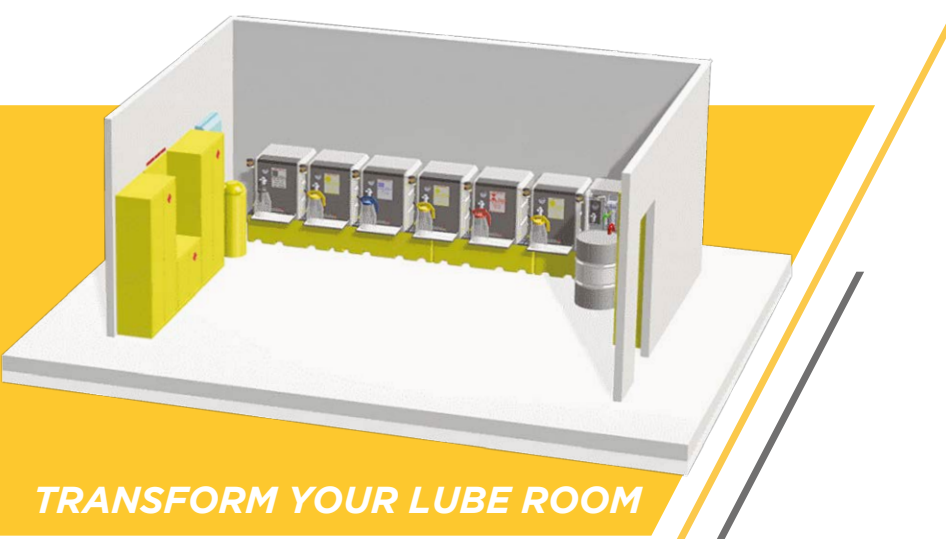

TRANSFORM YOUR LUBE ROOM



SYSTEM SPECIFICATIONS & DIMENSIONS

- 1. Desiccant breather
- 2. Poly-tank
- 3. Oil filter
- 4. Air operated oil pump
- 5. Air supply
- 6. Drip tray
- 7. Oil dispensing tap
- 8. Oil meter
- 9. Tank oil level
- 10. Male quick connect



743 mm - 29.25 in

**WALL MOUNT
(NO RESERVOIR)**

188 mm - 7.47 in

288 mm - 11.28 in

565 mm - 22.25 in



800 mm - 31.44 in

700 mm - 27.6 in

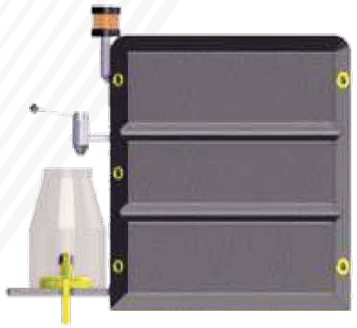

800 mm - 31.44 in

288 mm 700 mm - 27.6 in
11.28 in



1600 mm - 63 in

700 mm - 27.6 in



1600 mm - 63 in

288 mm 700 mm - 27.6 in
11.28 in

65 GALLON (250 LITER)

130 GALLON (500 LITER)

BOOST YOUR LUBE ROOM



To further minimize cross-contamination when storing and transferring lubricants, match your Luster™ Lubrication Storage System with a dedicated OilSafe Color-Coded Transfer Container; Drum and Lid, Drum Label Kit and Fluid Identification Label. All you do is designate one set per lubricant and label all equipment with the appropriate lubricant identification.

OilSafe Color-Coded Transfer Containers with Fluid Identification

Precise-pour transfer containers eliminate spills and slowdowns.

- Robust lids available in 5 lid sizes/styles with push-button air intake valves and quick twist spouts for fast, smooth pumping and pouring.
- Fully interchangeable, tough and comfortable to handle drums available in 5 sizes.
- Drum Label Kits designed to match and fit your lid with drum and protect the fluid identification label.
- Customized Fluid Identification Labels accurately identify fluids from storage, to intermediate container, to the point of use.



Available in 10 different colors -
Transfer Lid, Drum Label Kit, Custom Fluid Label



ORDER YOUR LUSTOR SYSTEM TODAY

whitmores.com/lustor
Contact sales@oilsafe.com or your local sales representative.



whitmores.com • jetlube.com

