



## Quicklub<sup>®</sup> Maintenance



# Contents

	Pages
Introduction-----	3
Benefits from Automated Lubrication -----	3
The Lincoln Quicklub Pump-----	3
Glossary of Terms-----	4 - 5
System Operation (Non-Monitored) -----	6
System Operation (Monitored) -----	7
Divider Valve Operation -----	8
System Startup -----	9
Daily Walk-Around Inspection-----	10
Troubleshooting Guide -----	11
Troubleshooting a Blockage-----	12 – 13
Quick-Fill (Filling Reservoir) -----	14
Monitored Pump PC Board indicator LED's -----	15
Non-monitored Pump PC Board indicator LED's -----	16
Pushbutton Fault Light Indicator -----	17
Manually Lubricating Bearings -----	18
Remote Lube Fitting -----	19
Spiral Wrap (Protection for lube lines)-----	20
Special Guarding (Protection for lube lines)-----	21- 22
Tapping Lubrication Points -----	23

## **Introduction**

This manual has been assembled to assist the operator in understanding and maintaining the Lincoln Quicklub system. It should be reviewed periodically so the operator becomes familiar with the nuances of the lube system. The manual shows some details about a typical installations followed by system maintenance and trouble shooting techniques.

The manual has a section that shows how our progressive lube system operates. A schematic diagram shows how the lube progresses from the pump to the primary valves, then to the secondary valves and finally to the bearing points.

When a Lincoln lube system is installed, quality and system robustness is the number one priority. Quicklub lubrication systems are proven to increase the life of pins and bushings, and decrease labor costs associated with manual lubrication. When a system is installed, items such as machine articulation, type of material machine handles, climate, and other operating conditions that could damage the system are taking into consideration.

## **Benefits From Automatic Lubrication**

- Gain 30 to 45 minutes per day of increased productivity for each machine by lubricating while machine is in service.
- Improve bearing life and reduce maintenance downtime due to repairing damaged bearings.
- Reduce bearing wear by delivering smaller, more frequent amounts of grease to each bearing.
- Reduce grease consumption by delivering the required amount of grease.
- Improve safety by eliminating the daily practice of climbing all over machinery to lubricate bearings. This can be extremely difficult in severe weather conditions.

## **The Lincoln Quicklub Pump**

Designed for the harsh environment of the construction markets, Quicklub pumps are loaded with features:

- Available in 12, 24 VDC and 120 VAC.
- Capable of dispensing #2 grease (oil systems available)
- Optional low-level alarms and system operation alarms with warning lights in the cab.
- Reservoir (2-, 4-, 8- or 15-Liter) can be refilled through a grease fitting, typically every 150-300 hours of operation.
- All pumps have high-pressure capability to ensure grease is delivered to each component.
- A blocked lube point can be detected at the pump or in the cab with the optional alarm and warning light. A buzzer can also be added as an alarm.
- Pump controls run-time and built-in-timer.
- Data Logger models available that store information on system operation history and can be connected to "Produce Link/GPS" to remotely notify if the system requires service.

## Glossary of Terms

**Automated Lubrication System (ALS)** – A pump supplies a number of bearings with lubricant via a system of transmission lines and divider valves.

**Closure Plug** – A threaded plug used to purposely block lubricant from exiting a valve outlet. This lubricant will move down to the next outlet.

**Cycle Indicator Pin** – Visual indication pin attached to a valve piston on the divider valve (see below). The pin is located on the side of the divider valve that moves in and out as grease flows within the valve. A cycle indicator pin is not necessarily present on all divider valves. Divider valves without cycle indicator pins are available.

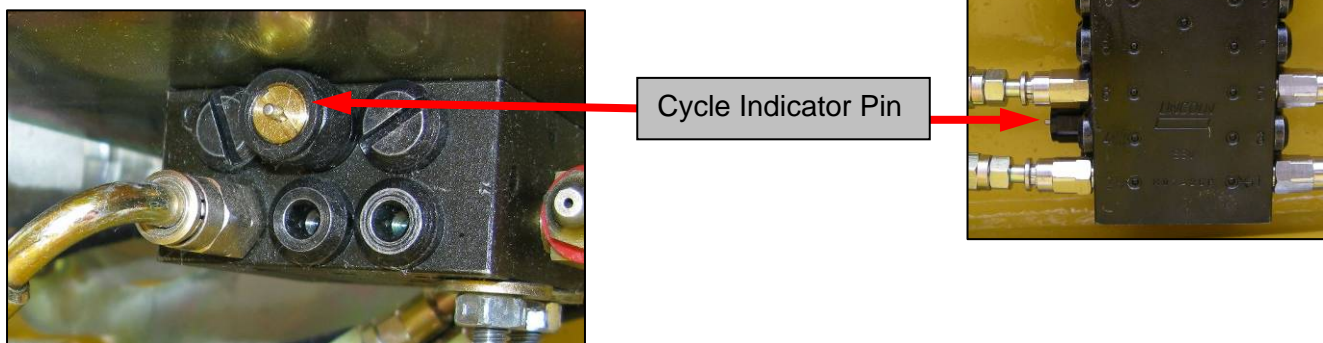

**Cycle Rate** – Amount of time it takes for every valve to cycle at least once.

**Distribution block** – See divider valve

**Divider Valve** – A Quicklub® divider valve is a proportioning device consisting of a minimum of three pistons. A primary divider valve is the first divider valve downstream from the lube pump. A secondary divider valve is any divider valve receiving lubricant from the primary divider valve. (A.k.a. distribution block, metering valve or SSV valve)

**Feed Line** – Tubing or hose going from a divider valve directly into a terminating lubrication fitting.

**Fitting** – Hardware used to connect hose or tube to lubrication port on equipment.

**Lube Event** – Depending on the Quicklub® pump that is used, it is the duration the pump is pumping grease. On a monitored pump, the lube event duration is controlled by a proximity switch. On the non-monitored pumps, the lube event duration is controlled by setting the “on” and “off” times via the dials on the PC board.

**Metering Valve** – See divider valve.

**Monitored Pump** – A Quicklub® pump that utilizes a proximity switch to monitor and end the lube event. The pump requires that the “off time” be set on the PC board, which is accessible from the front side of the pump. The “off time” is the length of time between lube events (pump operation).

**Non-monitored pump** - A Quicklub<sup>®</sup> pump that has its “on” and “off” time set by the red and blue dial switches on the PC board, which is accessible from the front side of the pump. The operation of the pump relies solely on the internal timer and its dial settings.

**Outlet** - Each outlet on a Quicklub<sup>®</sup> divider valve dispenses .012 in<sup>3</sup> per cycle. If an outlet is plugged, the lubricant will be diverted to the next outlet down allowing proper proportioning of lubricant to all lubrication points.

**Pressure Relief Valve** – Located at the outlet side of each pump element. It is a valve that limits the pressure in the system to a maximum value (3500psi). If pressure from the pump exceeds this value, the valve opens and lubricant is bled off to the atmosphere. A blockage in the system will cause an elevated pressure in the system.

**Primary Divider Valve** – First divider valve downstream from the lube pump, distributes lube to secondary valves.

**Proximity Switch** – A switch device that can be inserted into a divider valve and triggered by the piston movement inside the valve. A cycle consists of the piston moving two times (out and back).

**Pushbutton** – Optional accessory on Quicklub systems that alerts the operator of a fault and allows the operator to trigger an additional lubrication cycle. Usually mounted in the cab for visibility.

**Secondary divider valve** – Any divider valve receiving lubricant from the primary divider valve.

**SSV Valve** – See divider valve.

**SSV-D Valve** – A divider valve with adjustable outputs.

**Supply Line** – Hose from the pump to primary valve and hose from the primary valve to any secondary valve.

## System Operation (Non-Monitored System)

The key components of the Quicklub Non-Monitored system are:

1. **Pump** with an **Integrated Timer**. The Integrated timer controls the “**On Time**” and “**Off Time**” of the pump.
2. Divider valve network consisting of a **Primary Valve** and **Secondary Valves** with attached **Cycle Indicator Pin**.
3. A lubrication event is initiated by actuating the pump via the **Integrated Timer** based on a preset “pause time” or time between lubrication events.
4. The **Pump** dispenses lubricant to the primary divider valve.
5. The **Primary Valve** distributes the lubricant to the secondary valves.
6. The **Secondary Valves** distribute and dispense lubricant to the lubrication points.
7. Lubricant flow through the divider valves actuates the **Cycle Indicator Pin** for a visual inspection of proper operation.
8. The pump will run for the preset On-Time
9. The controller now begins countdown for the next lubrication event.

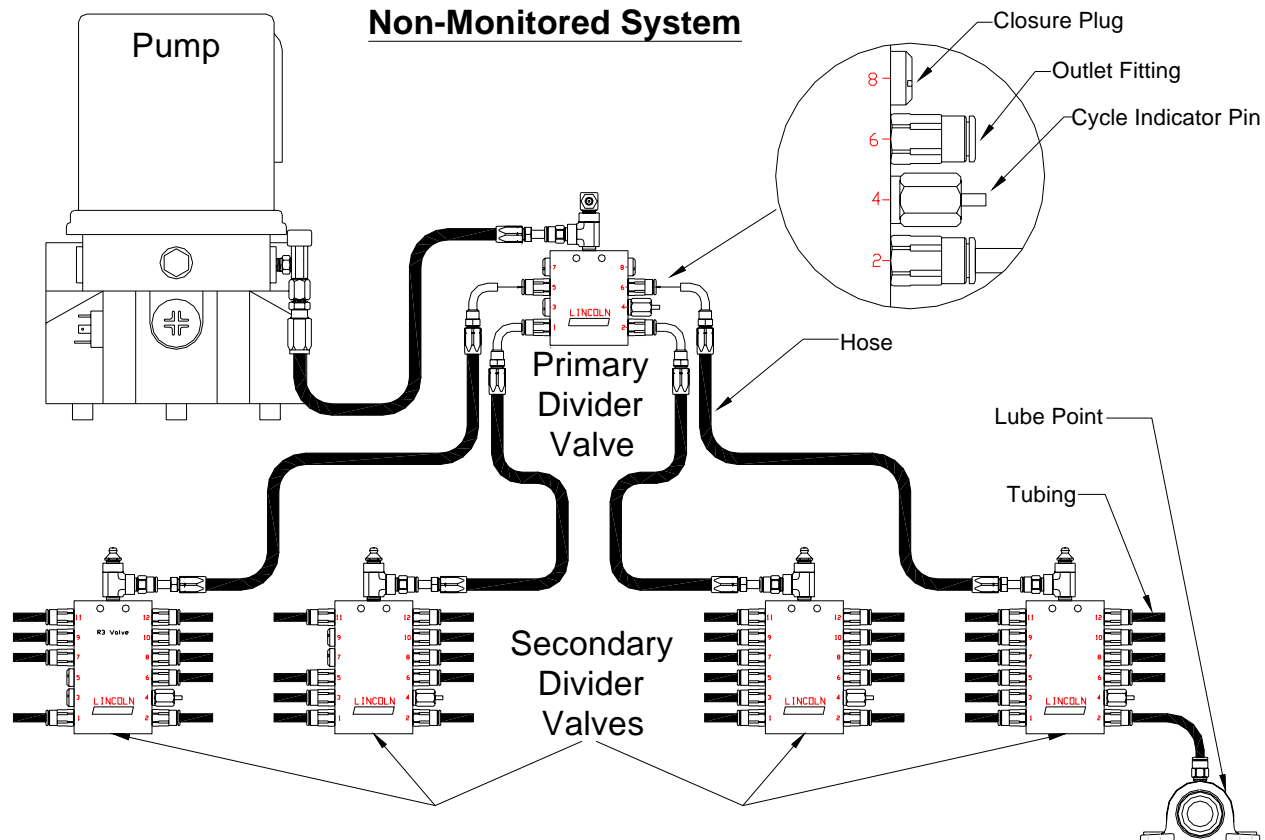

## System Operation (Monitored System)

The key components of the Quickclub Monitored system are:

1. **Pump** with an **Integrated Timer**. The Integrated timer controls the “**Off Time**” of the pump.
2. Divider valve network consisting of a **Primary Valve** and **Secondary Valves** with attached **Cycle Indicator Pin**.
3. A lubrication event is initiated by actuating the pump via the **Integrated Timer** based on a preset “pause time” or time between lubrication events.
4. The **Pump** dispenses lubricant to the primary divider valve.
5. The **Primary Valve** distributes the lubricant to the secondary valves.
6. The **Secondary Valves** distribute and dispense lubricant to the lubrication points.
7. Lubricant flow through the divider valves actuates the **Cycle Indicator Pin** for a visual inspection of proper operation.
8. The pump will run until the proximity switch reads one full cycle of the piston. The proximity switch can be attached to any block outlet in the system.
9. The timer now begins countdown for the next lubrication event.
10. The Pushbutton/Fault light will blink if the pump reservoir is low on grease or if there is a blockage in the system.

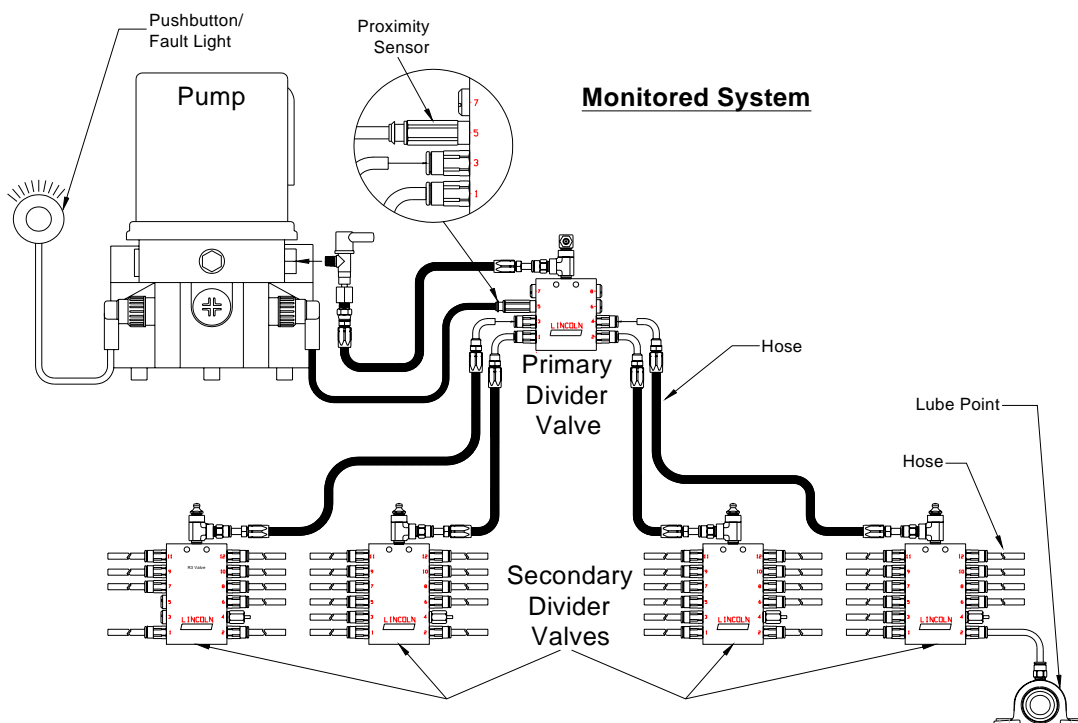

## Divider Valve Operation

At the heart of every Quickclub System is the metering valve or progressive distributor block, designed to positively meter the input of lubricant (oil up to NLGI #2 greases) out to the connected number of lubrication points irrespective of distance and back pressure. The inlet passageway is connected to all piston chambers at all times with only one piston free to move at any one time.

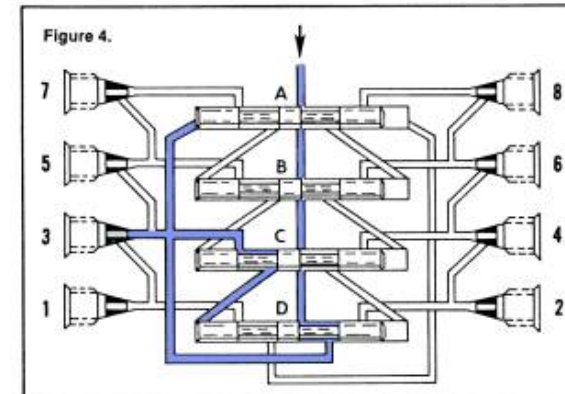
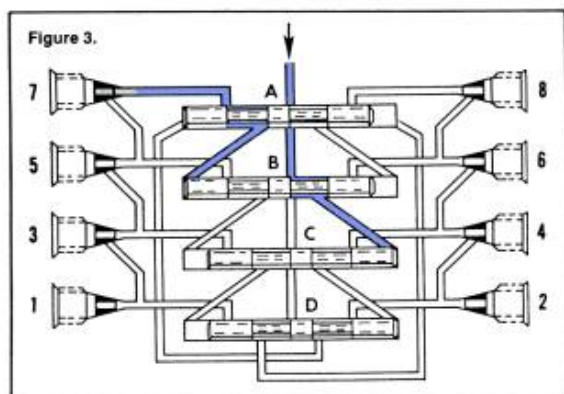
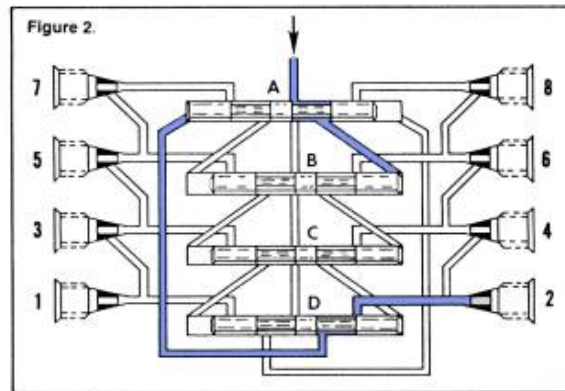
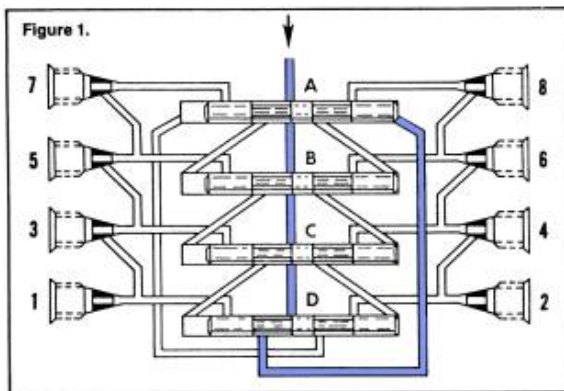

- With all pistons at the far right, lubricant from the inlet flows against the right end of piston A (fig. 1).
- Lubricant flow shifts piston A from right to left, dispensing piston A output through connecting passages to outlet 2. Piston A shift directs flow against right side of piston B (fig. 2).
- Lubricant flow shifts piston B from right to left, dispensing piston B output through valve ports of piston A and through outlet 7 (fig. 3).
- Lubricant flow shifts piston C from right to left dispensing piston C output through valve ports of piston B and through outlet 5.
- Piston C shift directs lubricant flow against right side of piston D (not illus.)
- Lubricant flow shifts piston D from right to left, dispensing piston D output through valve ports of piston C and through outlet 3.
- Piston D shift directs lubricant through connecting passage to the left side of piston A (fig. 4).
- Lubricant flow against left side of piston A begins the second half cycle which shifts pistons from left to right, dispensing lubricant through outlets 1, 8, 6 and 4 of the divider valve.



## **System Start-up**

The following checklist has been developed as an aid in verifying proper installation and operation of the Quicklub Onboard Grease System. By completing the steps outlined below, the operational readiness of the system and resulting extension of the component life of all points connected to the system will be insured.

- Apply grease gun (manual or pneumatic) to the grease fitting located on the Primary valve and each secondary valve inlet. While pumping grease through the system, cycle the indicator pin on the primary metering valve a minimum of 15 times. NOTE: Grease gun nozzle and grease fitting should be thoroughly cleaned before lubricating to prevent flow of contaminants into the lube system.
- Inspect primary valve supply and outlets for grease discharge. If leakage is detected, tighten the fittings.
- Continue to cycle the system until fresh grease appears at each lube point.
- Inspect each lube point fitting for leaks. Correct any leaks by firmly pushing tube into the fitting until seating occurs, or tighten the threaded fittings for components connected with hose.
- Operate the equipment through its complete range of motion, inspecting for unrestricted movement of tube and hose. Correct any problems of rubbing, chaffing or kinking.
- Inspect all hose and tube that is not covered with some type of protective wrap. Wrap any tube or hose that would be susceptible to damage from rubbing or chaffing.
- Inspect all hose and tube connected to moving components. Insure that adequate hose or tube is provided to allow unrestricted movement to these moving lube points.
- Verify proper pump operation and verify time setting by activating pump with the green activation button located on the face of the pump control panel. Activate the pump at least three times to insure proper operation.
- After the machine is in operation for a period of time (approx. 80 hours), you may find you need to adjust timing to a shorter or longer period based on the operating conditions.
- Fill the reservoir with selected grease by filling at the grease fitting located on the face of the pump reservoir.

## **Daily Walk-Around Inspection**

The Lincoln Industrial Quicklub automated lube system components are designed, engineered, manufactured and assembled to the highest or quality standards. This lube system requires little or no maintenance, however, to ensure maximum reliability and to realize maximum service life of all components, it is recommended that a **daily walk-around inspection** be performed.

The daily walk-around inspection should include the following:

- Observe lubricant level in reservoir. Fill reservoir if it is low.
- Inspect high pressure relief at pump element, noting any lubricant buildup. If buildup is observed, correct this problem by determining cause of blockage.
- Inspect all valve and lube point connections to verify that no leaks are occurring.
- Inspect supply/feed lines to insure that no breaks or leaks have occurred.
- Inspect lube points to ensure that all lube points have a **“fresh grease appearance.”**
- Check pump operation by depressing push-button located in base of pump for two seconds to initiate a manual lube event. This will verify that pump is working (ignition switch must be on).
- Report or repair any problems found in this walk-around inspection immediately.

**NOTE:** Operator to confirm operation of electric pump while machine is in service.

**NOTE:** Report or repair any problem detected from daily inspection.

## TROUBLE SHOOTING GUIDE:

SYMPTOM	PROBABLE CAUSE	SOLUTION
1. Pump will not operate.	Not receiving voltage.	Check fuses, timer and electrical supply. Check the electrical supply to the pump. If the pump receives no current, trace to the electrical source and repair.
	Blocked pump cam.	Replace the pump motor if no blockage is identified.
2. The pump motor is running but there is no grease being discharged.	Air pocket at pump element inlet.	Disconnect the main delivery hose from the pump outlet. Run the pump until solid grease (no bubbles) flows from the outlet. If solid grease does not discharge after 20 minutes of operation, the pump inlet is blocked with a contaminant. <b>NOTE:</b> Depending on operating temperatures and types of grease, it may require 10 minutes to achieve full volume at the outlet.
	Blocked Pump inlet.	Remove the pump element from the pump body and inspect the suction inlet port for foreign particles. Remove any particles found. Reassemble the pump and element and cycle the pump. If the pump element does not discharge grease, replace the pump element.
3. Pump was operated with an empty reservoir.	No grease	Fill the reservoir to the "max" level and press the manual reset button. Disconnect the main delivery hose from the pump and watch grease flow until solid grease (no air bubbles) is discharged. Reconnect the main delivery hose to the pump outlet.
4. Grease is discharged at the relief valve.	Blockage in the metering valves, hose, tube or connected component.	Switch the pump on and loosen each outlet in the primary valve one at a time. The blocked outlet will start discharging grease and the indicator pin will index. Retighten all of the outlets on the primary valve. Trace the hose that discharged grease to its secondary valve. Repeat the process of loosening each outlet one at a time until the blocked feed line is detected. Retighten all outlets. Repair the component blockage if found. If a metering valve is creating the blockage, replace the metering valve.
5. Indicator pin on the primary valve does not move.	Refer to #4.	Refer to #4.
6. Lube point not receiving grease.	Hose or tubing is cut or has chaffed through.	Replace the complete hose or tube. Or: If <u>Tube</u> is broken, cut tube at break and repair using tube union (part number 244058). If <u>Hose</u> is broken, cut ends at the break and install new reusable hose ends (part number 246002) and screw into a 1/8" NPT female connector (part number 67063).

## Troubleshooting a Blockage in Lincoln Quicklub® Systems

### Description

In a Lincoln Quicklub® Lubrication System, free flow of lubricant from the pump through the transmission system and the bearings is necessary. If any portion of this transmission system (a divider valve, line fitting or any bearing) does not freely accept and pass its portion of the lubricant a blockage has occurred. This blockage will cause a higher than normal pumping pressure to be developed by the pump. Depending on the application or system design, this blockage with its resultant high pump pressure will usually cause a complete loss of lubricant flow into the total system and no bearing will be receiving lubricant. The loss of flow due to a blockage is first indicated with the higher than normal system pressure that is developed by the pump as it attempts to overcome this blockage. The standard pressure relief valve (270864) is rated for 3900 psi.

This abnormally higher pressure that is a result of a blockage is limited, isolated, and signaled through the use of various performance indicators, reset and relief, incorporated into the system design.

If a blockage exists in a Quicklub lubrication system it is caused by one of the following reasons:

- (1) Crushed transmission line in the System.
- (2) Blocked bearing in the system.
- (3) Improperly drilled fitting in the system.
- (4) Blocked divider valve in the system.
- (5) Clogged pump element

All servicing and disassembling should be carried out under the cleanest conditions possible. A blockage in a Quicklub system will be indicated by the fault light and by the pump element relief indicator, exhausting lubricant to atmosphere. Before proceeding as outlined, make a visual inspection of the system and check for crushed lines or improper divider valve installation. Verify that each divider valve outlet required to discharge lubricant can do so and that no plugs have been installed in an outlets one and two of any valve.

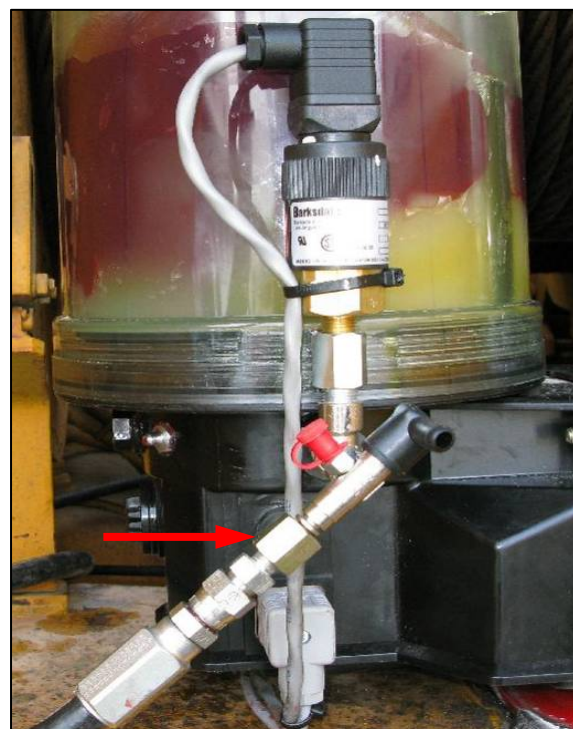

**Pressure Relief Valve mounted to pump**

## Procedure for locating blockage in system

1. Use a manual pump with a gauge. Fill the pump with clean, filtered lubricant common to the system. Connect the manual pump into the inlet of the primary divider valve and slowly operate pump. If system will not cycle freely below 1,500 PSI, see Step 2.
2. With pressure on the primary as outlined in step 1, remove one at a time each supply line (if the supply lines cannot be removed, remove outlet fittings starting from the bottom and working towards the valve inlet) and attempt to operate manual pump after each line is removed. Do not exceed 2,000 PSI. If pressure drops and primary cycles freely after a line is removed then blockage is downstream in the area that is being served from that outlet. See Step 3. If all feed lines are removed and primary will not cycle, blockage is in this divider valve. Note: When a feed line of a blocked area is removed a small shot of trapped lubricant will usually surge out of this outlet as the inlet pressure on the divider valve drops. If testing in Step 2 indicates a blockage in the primary divider valve, this divider valve must be replaced.
3. Testing accomplished in Step 2 has indicated the blockage is downstream of the primary divider valve. Reinstall the feed line into the primary valve and proceed to downstream secondary divider valve and repeat step 2 on the secondary valve. If lubricant can be discharged freely through the secondary valve, the blockage is in the supply line between the primary and the secondary valve.
4. If high pressure exists on one of the secondary outlets, blockage has been located. Look for crushed line, tight bearing, and improperly drilled fittings and/or lube inlet port. Correct as necessary.

## Contamination

If dirt, foreign material or any other form of contamination is found as the source of the blockage, clearing the blockage will only temporarily solve contamination blockage problems. The **source of the contamination must be eliminated for satisfactory service**. The reservoir must be inspected and cleaned if necessary. The reservoir filling method should be reviewed to eliminate any chance of foreign material entering the reservoir during filling. All lubricating systems require filtered lubricant.

## Grease Separation Blockage

If a hard wax or soap like material is found in the valve outlets, grease separation is occurring. This means that the oil is being squeezed from the grease at normal system operating pressure and the grease thickener is being deposited in the divider valve. Cleaning the divider valve will usually result in only temporarily solving the problem. Consult your lubricant supplier for recommendations on alternate lubricants and your local Lincoln Distributor to verify compatibility with centralized lubricating systems.

## Filling the Pump Reservoir (Use Filtered Lubricant Only !!)

**DO NOT fill the pump reservoir from the top. This is the quickest way to introduce debris and foreign material into the grease.**

**Note:** Dirt and foreign material are the worst enemies of any lubricating system.

## Quick-Fill Adapter Installation and Operation (Filling pump reservoir)



The Quick-Fill adapter is a device which replaces the standard grease fitting fill port with a high-flow port for use with a standard grease gun.



**Step 1:** To install the quick-fill adapter, remove the standard fill port located in the front of the pump.



**Step 2:** Insert the Quick-Fill adapter into the fill port. Hand tighten only.



**Step 3:** To fill the reservoir, remove the grease gun's pump head assembly from the container tube (Standard procedure used to install a lubricant cartridge).



**Step 4:** Insert a new cartridge of grease into the grease gun's container tube and assemble into the quick-fill adapter.



**Step 5:** Unlock the follower handle making sure the handle is engaged with the follower. Push the follower rod handle into the container. This action will dispense the entire cartridge of grease into the reservoir. Repeat until the reservoir is full. Replace quick-fill cap.

## Monitored & Non-Monitored Pump Indicator LED's

The 203 style Monitored and Non-Monitored pumps have LED's on the circuit board that indicate the pump is receiving power to the circuit board and that the pump is actually pumping grease. The PC board is accessed by removing the plastic plug located on the front of the pump. The LED's are located on both sides of the rotary switches.

### Monitored Pump (uses proximity switch)

LED lights up when power is applied to the PC board.

LED lights up when the pump is in operation.

Manual Lube Pushbutton  
Depress for 2 seconds to initiate a manual lube event

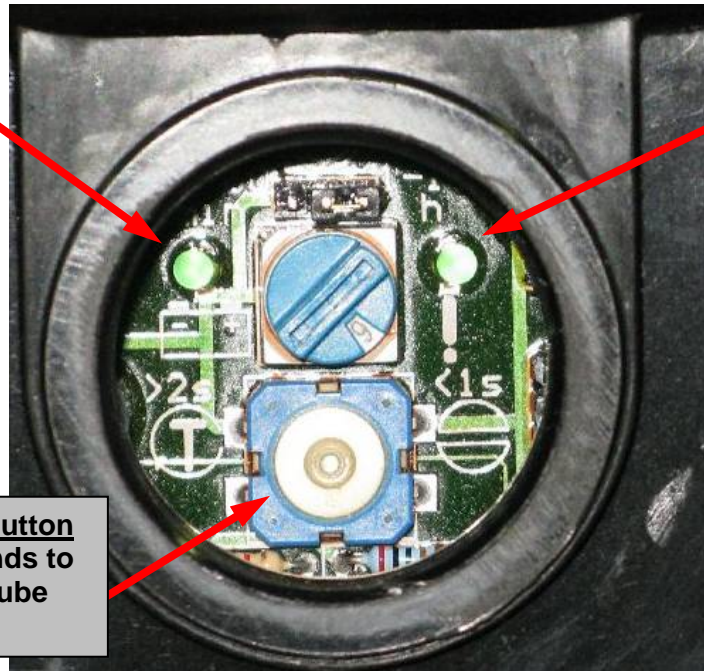

Remove the plug on the front to gain access to the PC board.

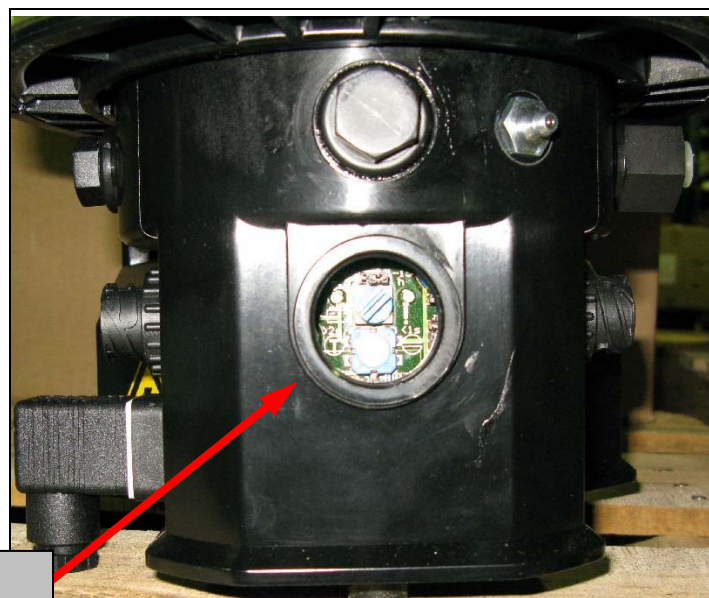

## Non-Monitored Pump

The non-monitored pumps have two rotary dial switches on the PC board to set the **On** and **Off** time. “**On Time**” is how long the pump will run and the “**Off Time**” is the interval between run times. The Blue dial on the left sets the Off or Pause time. The Red dial on the right sets the On time. Notice the LED’s on both side of the switches. Refer to the pump service page for the codes to set each.

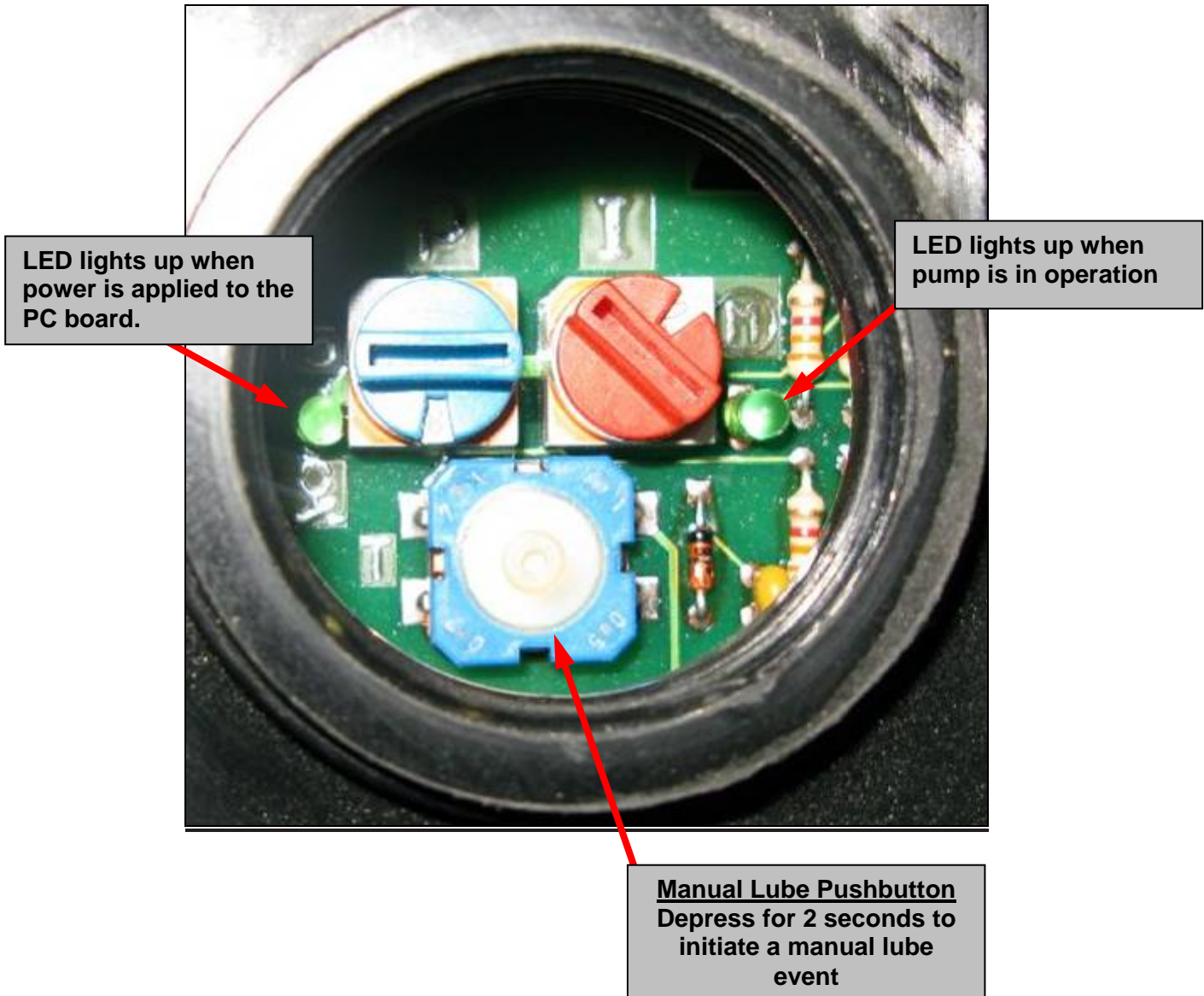



## Pushbutton Fault Light Indicator

An optional pushbutton/fault light can be mounted in the cab that monitors the status of the lube system. The LED uses different flashing frequencies depending on the status of the lube system (i.e. running, not running or in fault). The service manual for the particular pump will show what fault is associated with each flashing frequency.

1. **Manual Lube:** By depressing the pushbutton for 2 seconds, the operator can initiate a manual lube event. The pump will stay on a pre-determined amount of time or until the proximity switch turns it off.
2. **Indication of operation:** The lamp will be on constantly.
3. **Fault Indication:** A flashing LED indicates a fault. Refer to the pump technical manual for the flashing frequency definitions of the various faults (i.e. low level, blockage or drive motor malfunction)

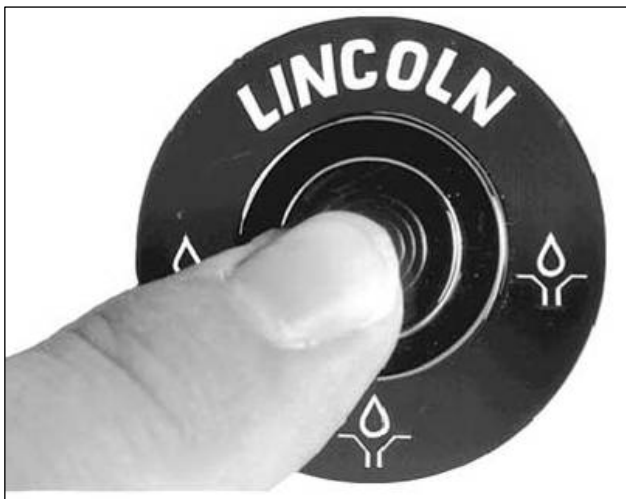

The Red pushbutton is used exclusively with the Data-Logger pumps. The status of the lube systems is indicated by whether the light is on or off.

**LED Off** – Indication of Operation

**LED On** – Fault in system (action required)

## Manually Lubricating Bearings using grease gun

If the need arises to manually lube the bearings, it can be done without the pump. A manual process is available using a grease gun.

There is a grease fitting located on all of the divider valves in a Quicklub system. Use a grease gun and attach the hose to the grease fitting. As grease is pumped into the valve, the bearings will be lubricated and the cycle indicator pin on the side of the divider valve will be cycling in and out.

The picture below shows a Lincoln battery operated Power Luber as the grease gun supplying the grease.

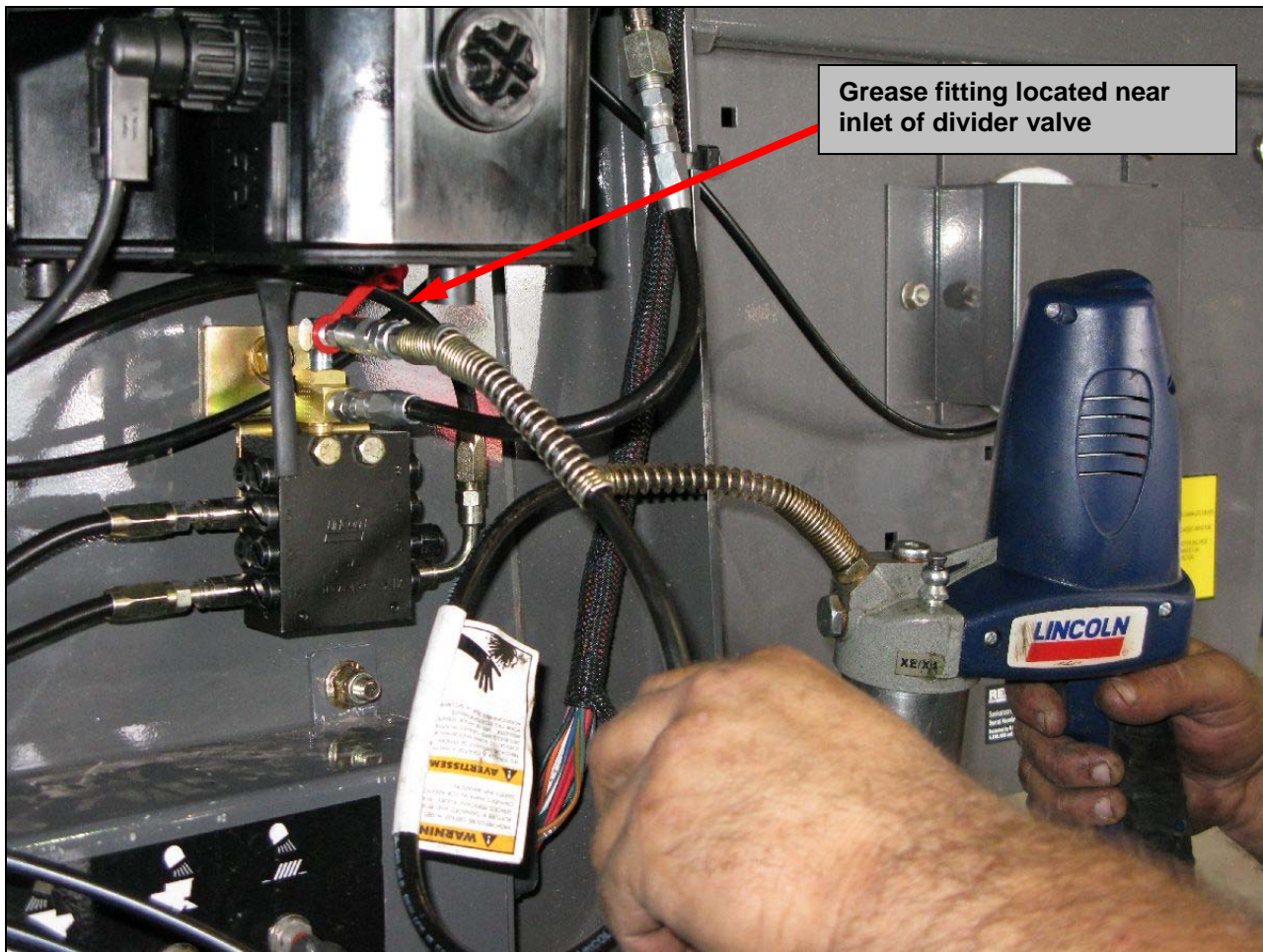

## Remote Fill Lube Fitting

Some large equipment requires that a **Remote Fill** fitting to be installed so the operator can refill the pump reservoir without having to climb on the equipment to access the pump. An example of when a remote fill fitting is used is excavators where the pump is mounted up high behind the cab. A separate grease line is routed to a fitting that is easily accessible from floor level

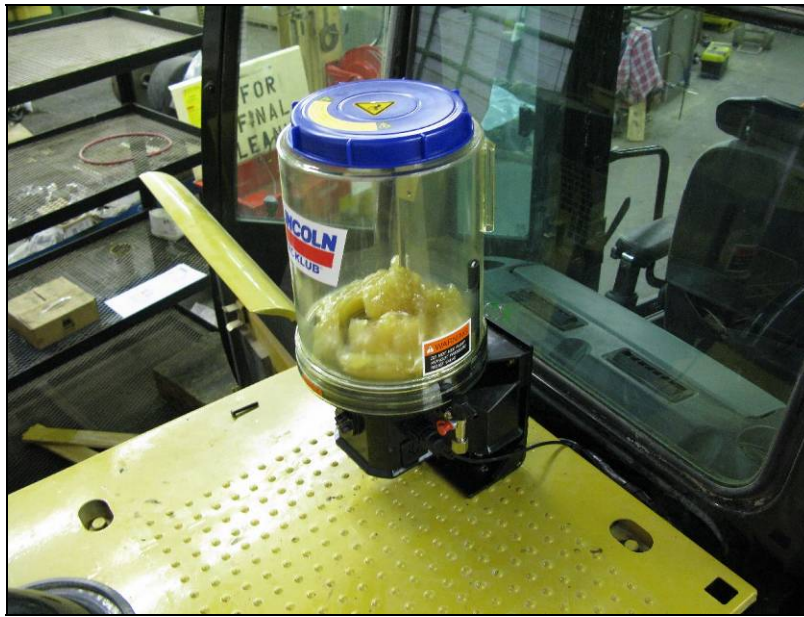

Pump located behind cab up high

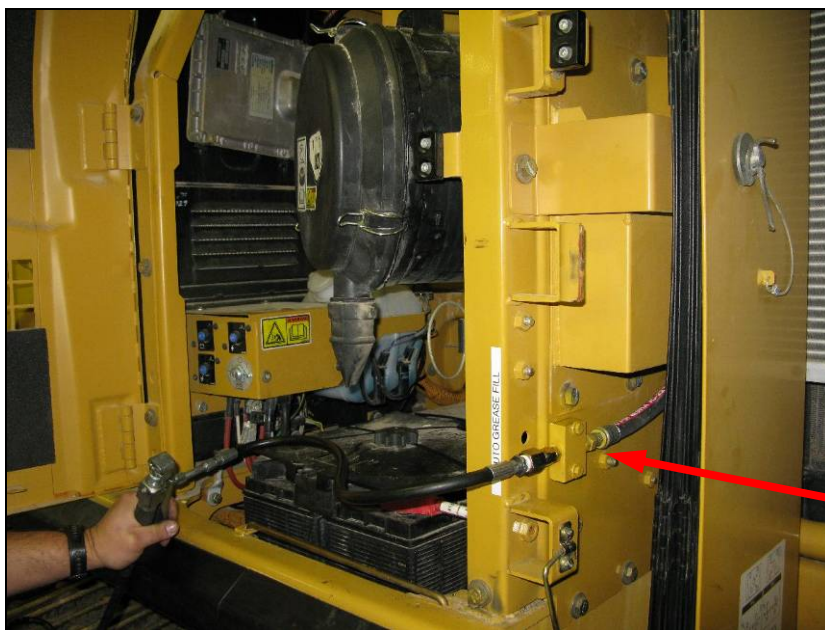

Remote fill fitting being filled with a grease gun by the operator while standing at floor level.

## **Spiral Wrap / Spring Coil / Sleeving**

Below are different kinds of line protection offered in a Quickclub system. Depending on the application determines the kind of line protection required.

Many times it is necessary for lines to be exposed to articulation, falling debris, abrasion, heat, etc. When these conditions exist Lincoln recommends protecting the lines with spiral wrap, spring coil, or nylon sleeving.

Spiral wrap (shown below) shields hose from abrasions and cuts, and is ideal for bundling tubing and hoses. Lines can also be individually spiral wrapped to allow for improved serviceability. Spiral wrap also helps to protect against kinking.

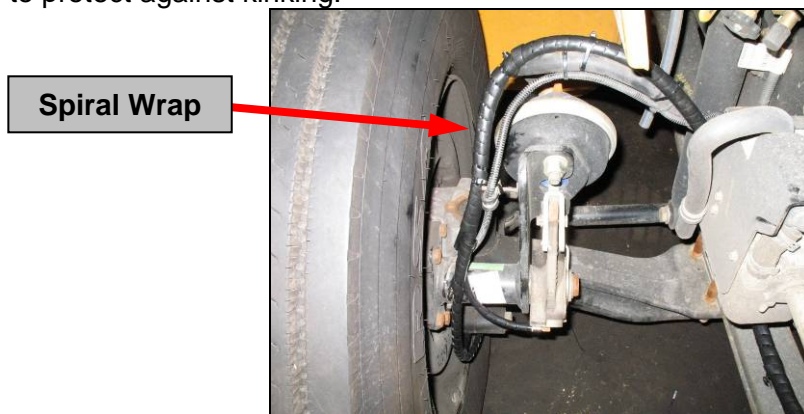

Spring Coil (lower left) is designed to prevent kinking and to prevent smashed lines. Use this product where lines may be subject to being struck by large falling debris. Spring coil should be used in conjunction with spiral wrap to prevent internal abrasion from the spring coil. After cutting the spring coil with a grinder or wire cutters make sure that the ends of the spring coil are not sharp to prevent hose damage or personal injury. Note: Use a 0.750" diameter p-clamp (part #270931) to secure the spring coil.



Nylon sleeving (above right) protects hose from abrasion and cuts. Lines can also be spiral wrapped to prevent internal abrasion.

## Grease Line Guarding

The following shows the different types of guarding that are used to protect grease lines. Again, depending on the application will determine the required guarding.

Additional guarding should be used for machines that operate in extreme conditions. Always check with the customer before welding or altering the machine. Always disconnect the battery of the machine before welding.

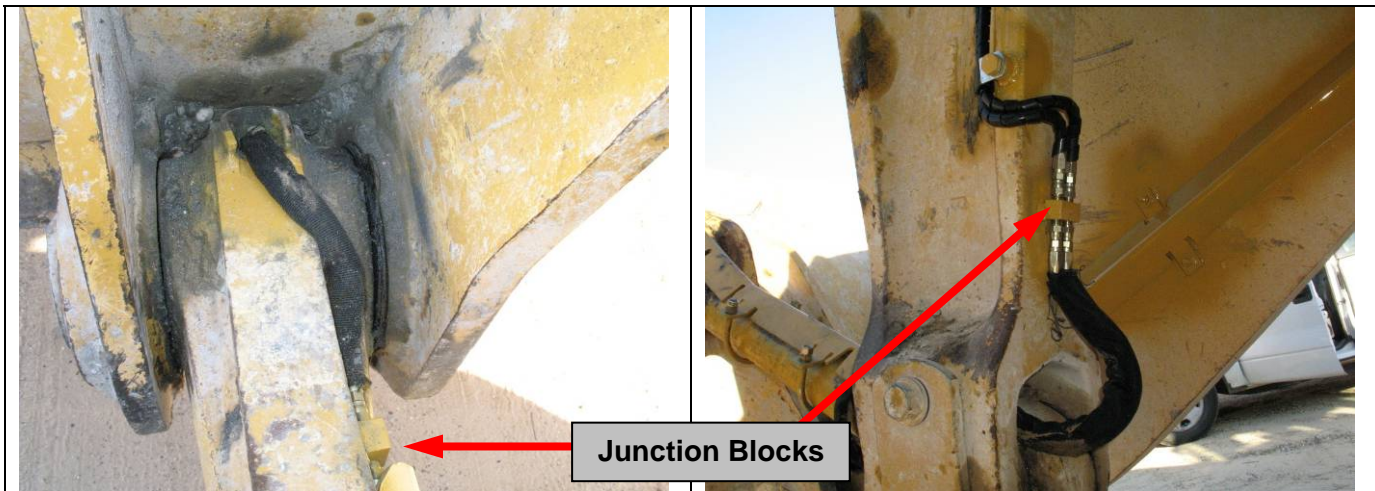

High impact and abrasion prone lubrication points with long lengths of hose should be shortened by adding a junction block away from the impact zone. This will allow for a very quick hose replacement should damage to the hose occur.

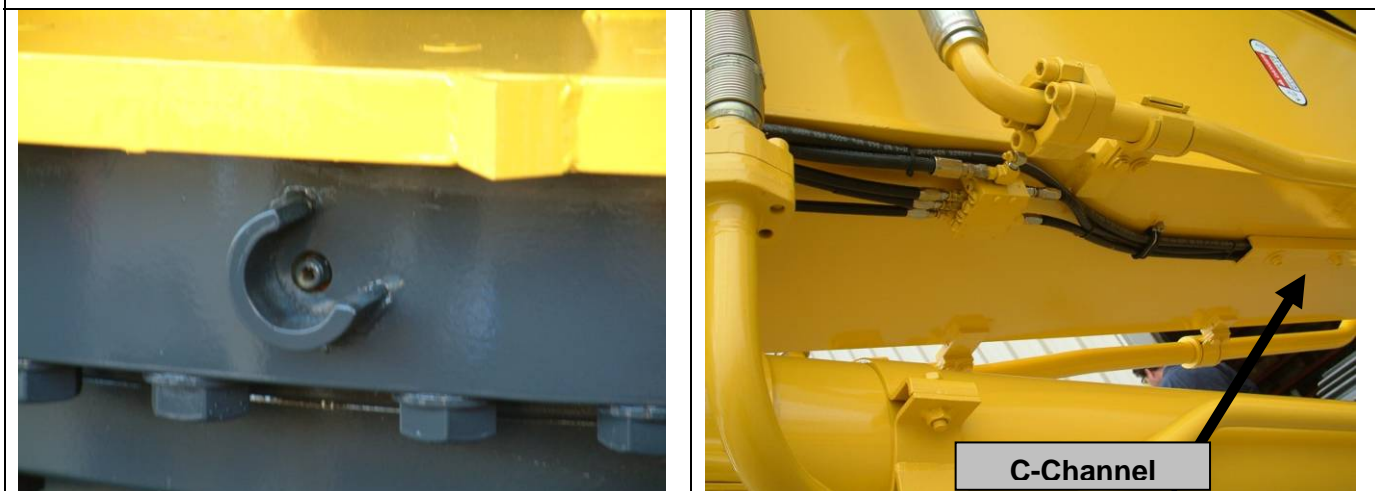

Turrets or C-Guards can be made by cutting a section out of a short piece of pipe.

C-channel can be bolted on and used for line guarding

## Grease Line Guarding (continued)

The following is another type of guarding that is used to protect lube lines on heavy construction equipment. It is attached to the frame using welded studs or stand-offs.

### Guarding that can be bent to fit around obstacles

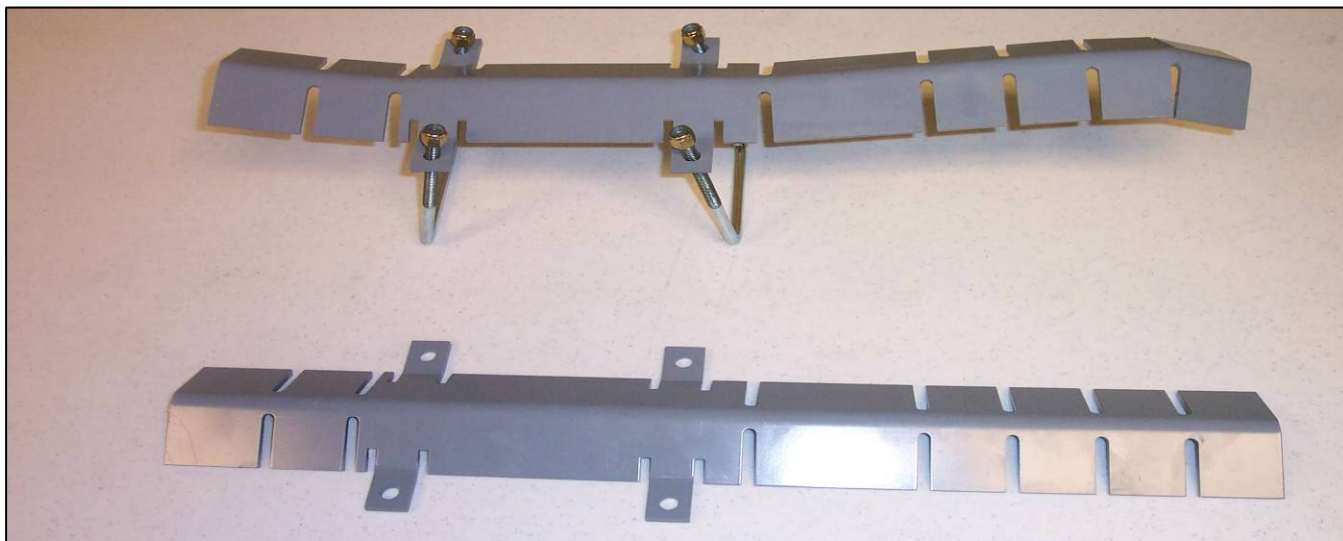

### Straight Guarding

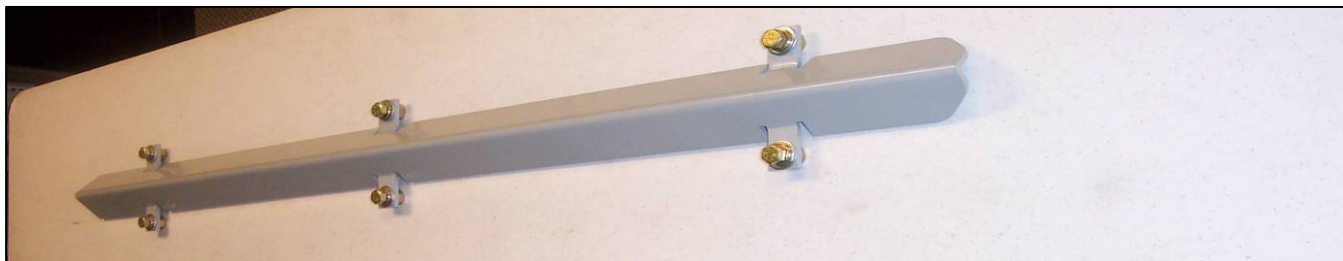

Guarding shown used on an excavator to protect lube lines in heavy use areas.



### Tapping Lubrication Ports (if necessary)

It is sometimes necessary to re-tap a lubrication port due to port damage or drive type fitting removal. Tapping oil should be used to ease the tapping process. Make sure that all metal filings are removed from the port prior to installing the fitting. Always check with the customer before altering the machine.

Fitting Thread Size	Tap Drill Selection for Standard Thread Fitting	Drill Size Selection for Spin Drive Fittings
1/4" -28	#3 (for soft metal, use #5)	"A" - .234" / 5.9mm Dia. *
5/16" -32	9/32"/7.1mm (for soft metal, use "J")	—
1/8" Pipe	1 1/32"/8.7mm (for soft metal, use "R")	3/8 - .375" / 9.5mm Dia. *
1/4" Pipe	7/16" / 11.1mm	—

<u>Drill ID</u>	<u>Decimal</u>
J	0.2770"
R	0.3390"
#3	0.2130"
#5	0.2055"

Zerk-Lock fittings (part# 270784) can be used for drive type fittings, but it is recommended that the fittings be removed and tapped to install a more reliable fitting.

Spin Drive (thread forming) fittings have special tapered drive heads for fast production line installation in untapped holes to save tapping cost. Spinning into the hole with a power wrench provides the most effective installation.

Drive type fittings are designed for fast production line installation in untapped holes. One method of removing drive type fittings is to use a small easy out tool with a drill and place the easy out tool into the ball check of the grease fitting and wear out the drive type fitting until it is able to be removed from the machine.

Loctite can be used on the threads of fittings to ensure that fittings do not vibrate loose.

