

OWNER/OPERATOR MANUAL

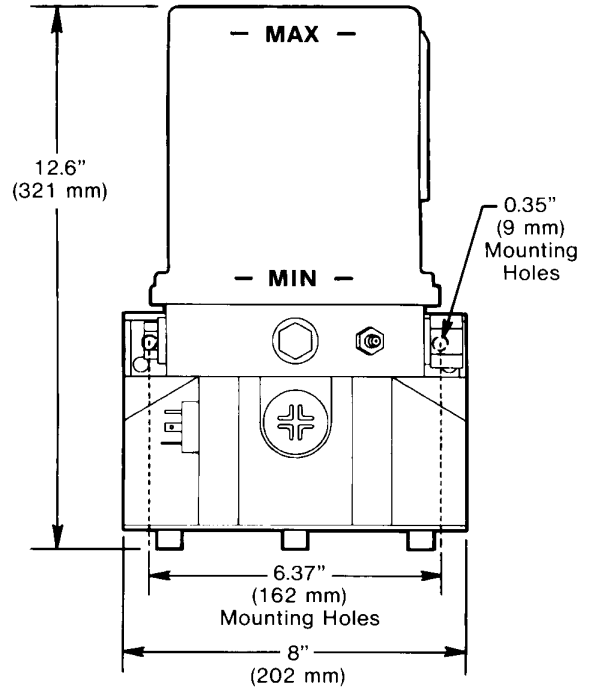
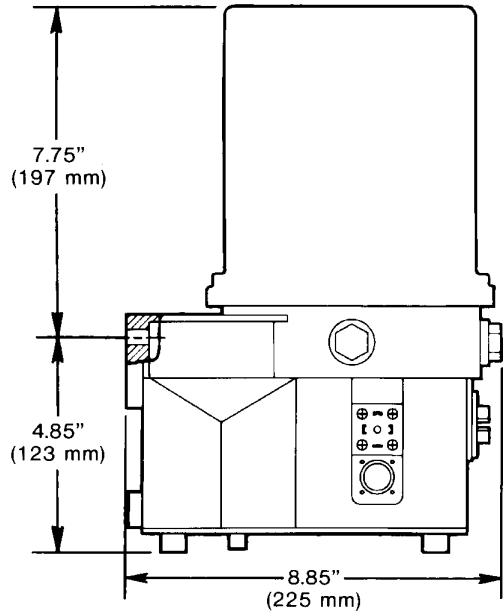

WARNING
Do Not use pump without pressure relief valve.

SPECIFICATIONS

Electrical Requirements

- Model 94012 12 VDC @ 3.5 amps
- Model 94024 24 VDC @ 2 amps

©Enclosure Rating..... IP 6K9K - Protected from water sprayed in all directions.

On Time 2 minutes minimum
30 minutes maximum
in 2 minute increments

Off Time 1 hour minimum
15 hours maximum
in 1 hour increments

Pump Output 0.146 cu. in./min (2.4 cm/min)

Outlet Connection..... 1/8" NPT (female)

Maximum Recommended

Operating Pressure 3600 psi (248 bar)

Reservoir Capacity..... 122 cu. in. (2000 cc)

Lubricant Greases up to NLGI grade 2
(depending on the operating
temperature and type of lubricant)

Temperature Range..... -13° F (-25° C) to +158° F (+70° C)

Pressure Relief Valve 4000 psi +/- 250 psi
(276 bars) +/- (17 bars)

© Indicates Change

DESCRIPTION

The chassis lube pump is electrically operated and used in a progressive type centralized lubrication system. The pump consists of a pump housing, electric gear motor, a timer and a plastic reservoir with stirring paddle. The high operating pressure allows the pump to supply lubricant up to NLGI 2 grease.

MOUNTING THE PUMP

Select an easily accessible place of installation which allows access to the timer and lubricant reservoir filler fitting. The pump must be mounted vertically on an even surface by means of two bolts.

TO FILL RESERVOIR

Fill the reservoir through the grease fitting located at the base of the reservoir, using a hand operated grease pump. Refill reservoir when grease reaches "MIN" mark located on the reservoir. Fill the reservoir up to the "MAX" mark located on the reservoir.

TO PRIME SYSTEM

Pump & Supply Line: After reservoir has been filled with recommended lubricant, loosen the supply line fitting. Operate the pump until lubricant flows from outlet, then tighten fitting.

Feed Lines: Pre-fill each feed line with lubricant before connecting to outlet of divider valve and bearing.

SYSTEM ACCESSORIES

Description	Qty.	Part No.
8 amp fuse	1	241052
8 amp fuse holder	1	241053
Lighted manual switch (12 VDC)	1	241419
Lighted manual switch (24 VDC)	1	241484
Remote manual lube kit	1	246322

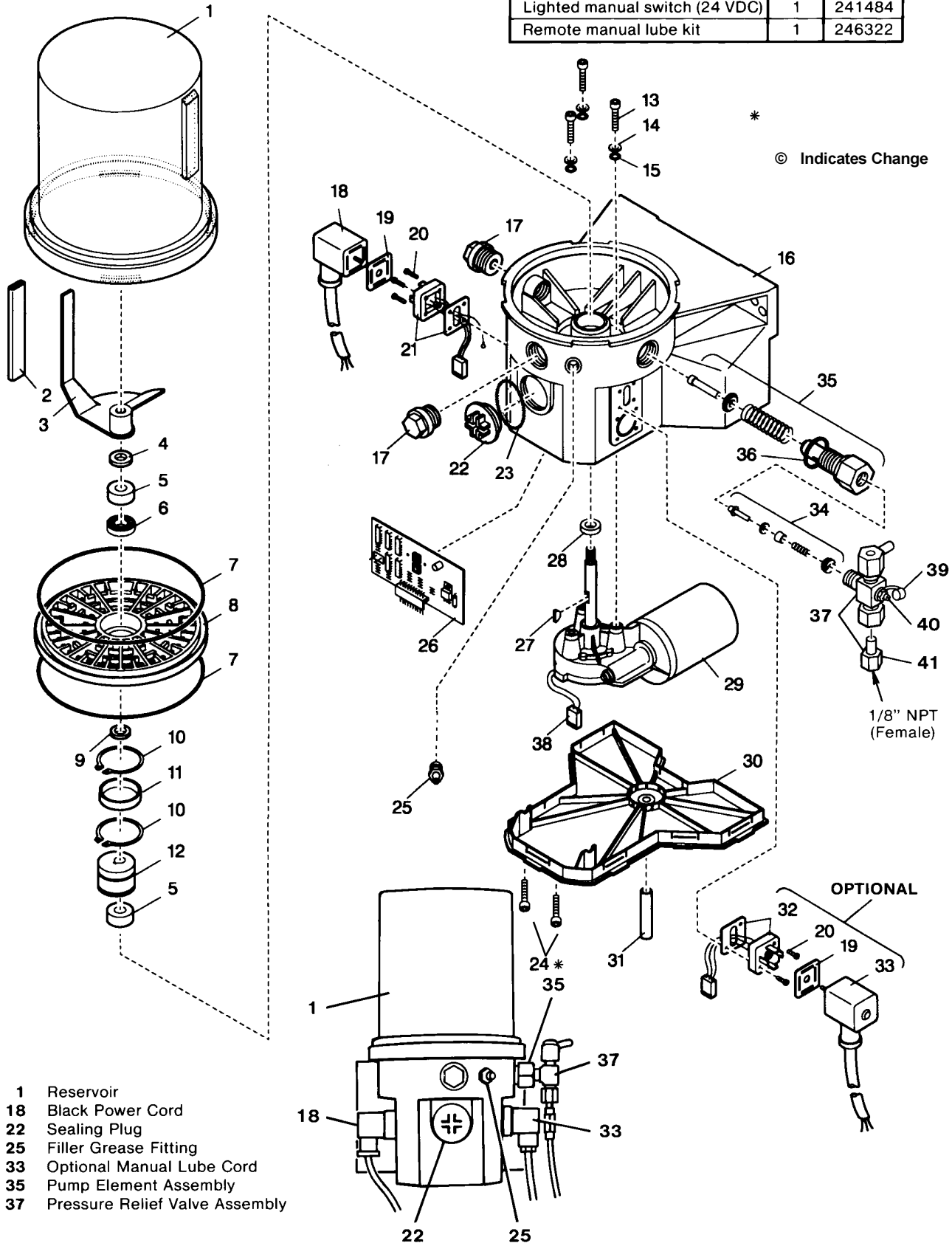

ELECTRICAL CONNECTIONS

Connect **black power cord** as follows:

Red wire connects to 8 amp fuse then to Battery (+).

White wire connects to Battery (-).

Blue wire connects to 8 amp fuse, to ignition switch, then to Battery (+).

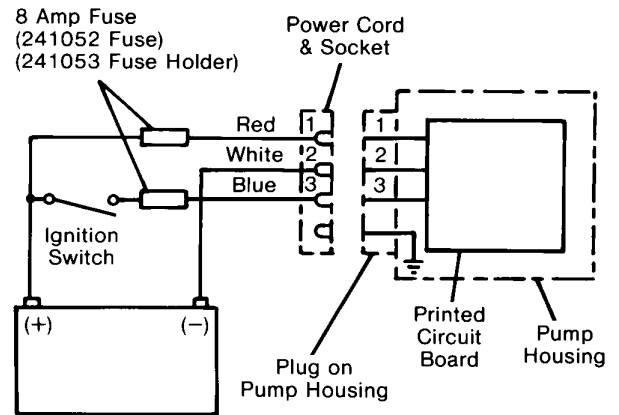

ITEM NO.	DESCRIPTION	QTY.	PART NUMBER /KIT NUMBER
1	Reservoir	1	part of Kit 246432
2	Hose	1	part of Kit 246433
3	Stirring paddle	1	part of Kit 246433
4	Washer	1	part of Kits 246433 & 246434
5	Bearing ring	2	part of Kit 246434
6	Bearing	1	part of Kit 246434
7	0-ring	2	246424, part of Kit 246432
8	Intermediate plate	1	246425
9	Shim	1	part of Kit 246434
10	Snap ring	2	part of Kit 246434
11	Inner ring	1	part of Kit 246434
12	Eccentric cam	1	246427
13	Screw	3	part of Kits 246435 & 246436
14	Washer	3	part of Kits 246435 & 246436
15	0-ring	3	part of Kits 246435, 246436 & 246437
16	Pump housing	1	246426
17	Closure plug	2	246422
18	Socket with cord	1	part of Kit 246429
19	Flat packing	1	part of Kits 246429, 246440, 246441 & 246431
20	Screws	4	part of Kits 246440 & 246441
21	Plug	1	part of Kit 246440
22	Sealing plug	1	246423
23	0-ring	1	219141382
24	Screw	10	206137967©
25	Grease fitting	1	5050
26	Printed circuit board	1	246420
27	Woodruff key	1	part of kits 246435 & 246436
28	Radial seal	1	part of Kits 246435, 246436 & 246437
29	12 VDC motor	1	part of Kit 246435
29	24 VDC motor	1	part of Kit 246436
30	Housing cover	1	246421
31	Hose	1	not sold
32	Plug	1	part of Kit 246441
33	Socket	1	part of Kit 246431
34	Check valve	1	part of Kit 600268762
35	Pump element	1	part of Kit 600268762
36	Gasket	1	part of Kit 600268762
37	Pressure relief ass'y.	1	249567©
38	Plug for motor	1	part of Kits 246435 & 246436
39	Grease cap	1	242125
40	Grease fitting	1	249568©
41	Adapter for relief assy.	1	249565©
42	Seal	1	249569 ©

REMOTE MANUAL LUBE PUSHBUTTON

If a remote manual lube pushbutton is required, order a 246322 Manual Lube Kit (consisting of a 32 ft. cord and plug) and:

for a 12 volt pump, order
241419 - Lighted Manual Lube Switch

for a 24 volt pump, order
241484 - Lighted Manual Lube Switch

IMPORTANT:

When using a Model 94012 or 94024 to replace an old style 103 pump with remote manual lube switch, only the 246322 Manual Lube Kit is required.

The wiring for the remote light used on the 103 pump must be changed for the new Models 94012 and 94024. The existing wire that connects the light to the Battery (-) must be disconnected. Reconnect it to the Battery (+).

© Indicates Change

TIMER OPERATION

The Off timer begins accumulating time when the ignition switch closes. When the Off timer reaches the preset value the pump will turn on. The pump remains activated for the period of time that is preset on the On timer.

When the ignition switch opens the Off timer will retain its accumulated time for a period of five days. When the ignition switch closes during the five day period, the Off timer will resume timing from the accumulated time it reached prior to the ignition switch opening. If ignition switch is not closed before the end of five day period, timer will begin with an On period.

Remove Sealing Plug (Item 22) to access manual lube switch, timer adjustments or to view the system LED's.

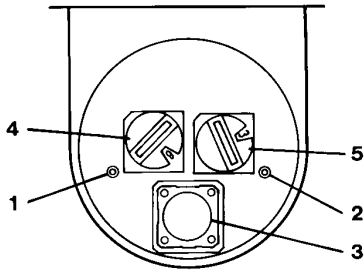

1. The LED marked "battery" lights when power is applied to the PC board.
2. The LED marked "motor" lights when pumping lubricant.
3. Depressing pushbutton for 2 seconds will initiate a manual lube event.
4. Off time rotary switch. Can be adjusted to 15 values (see chart below).
5. On time rotary switch. Can be adjusted to 15 values (see chart below).

IMPORTANT: Do Not use the Zero position located on the Off time and On time switches.

Off-Time Rotary Switch Setting	Interval Between Lube Cycles	On-Time Rotary Switch Setting	Pump will run for:
0	Will not run	0	Will not run
1	1 hour	1	2 minutes
2	2 hours	2	4 minutes
3	3 hours	3	6 minutes
4	4 hours	4	8 minutes
5	5 hours	5	10 minutes
6	6 hours	6	12 minutes
7	7 hours	7	14 minutes
8	8 hours	8	16 minutes
9	9 hours	9	18 minutes
A	10 hours	A	20 minutes
B	11 hours	B	22 minutes
C	12 hours	C	24 minutes
D	13 hours	D	26 minutes
E	14 hours	E	28 minutes
F	15 hours	F	30 minutes

© Indicates Change

SERVICE PARTS/KITS

Part No.	Qty.	Description	Item No.
249568	1	Grease fitting	40
5050	1	Grease fitting	25
242125	1	Grease cap	39
249567	1	Pressure relief assy.	37
246420	1	Printed circuit board	26
246421	1	Housing cover	30
246422	1	Closure plug	17
246423	1	Sealing plug	22
246424	1	O-ring	7
246425	1	Intermediate plate	8
246426	1	Pump housing	16
246427	1	Eccentric cam	12
249565	1	Adapter for relief assy.	41
246429	1	Power Cord Kit contains:	18
	1	Socket with cord	19
	1	Flat packing	
246431	1	Optional Manual Lube Cord Set contains:	19
	1	Flat packing	33
	1	Socket with cord	
246432	1	Reservoir Kit contains:	1
	1	Reservoir	7
	1	O-ring	
246433	1	Paddle Kit contains:	2
	1	Hose	3
	1	Stirring paddle	4
	1	Washer	
246434	1	Bearing & Seal Kit contains:	4
	2	Washer	5
	1	Bearing ring	6
	1	Bearing	9
	2	Shim	10
	1	Snap ring	11
	1	Inner ring	
246435	3	12 VDC Motor Kit contains:	13
	3	Screw	14
	3	Washer	15
	3	O-ring	27
	1	Woodruff key	28
	1	Radial seal	29
	1	12 VDC motor	38
	1	Plug for motor	
246436	3	24 VDC Motor Kit contains:	13
	3	Screw	14
	3	Washer	15
	3	O-ring	27
	1	Woodruff key	28
	1	Radial seal	29
	1	24 VDC motor	38
	1	Plug for motor	
246437	3	Housing Seal Kit contains:	15
	1	O-ring	28
	1	Radial seal	
246440	1	Power Plug Kit contains:	19
	4	Flat packing	20
	4	Screws	21
	1	Plug	
246441	1	Optional Manual Lube Plug Set contains:	19
	4	Flat packing	20
	4	Screws	32
	1	Plug	
600268762	1	Pump Element Assembly contains:	34
	1	Check valve	35
	1	Pump element	36
	1	Gasket	

RETAIN THIS INFORMATION FOR FUTURE REFERENCE

When ordering replacement parts, list: Part Number, Description, Model Number and Series Letter.
LINCOLN provides a Distributor Network that stocks equipment and replacement parts.

