



MFP

**AUTOMATION
ENGINEERING**

Full-system solutions. Total flexibility.

Who we are

- 2nd generation family-owned business
- \$40 million+
- 25 years in business
- On-site Parker Store
- Manufacturer
- 47,000 sq. ft. facility
- 80,000 skus in inventory
- CNC shop, Panel Assembly room, & Test facilities
- 5-10% growth annually
- Distributor

Who We Are

Video only plays when opened in PowerPoint

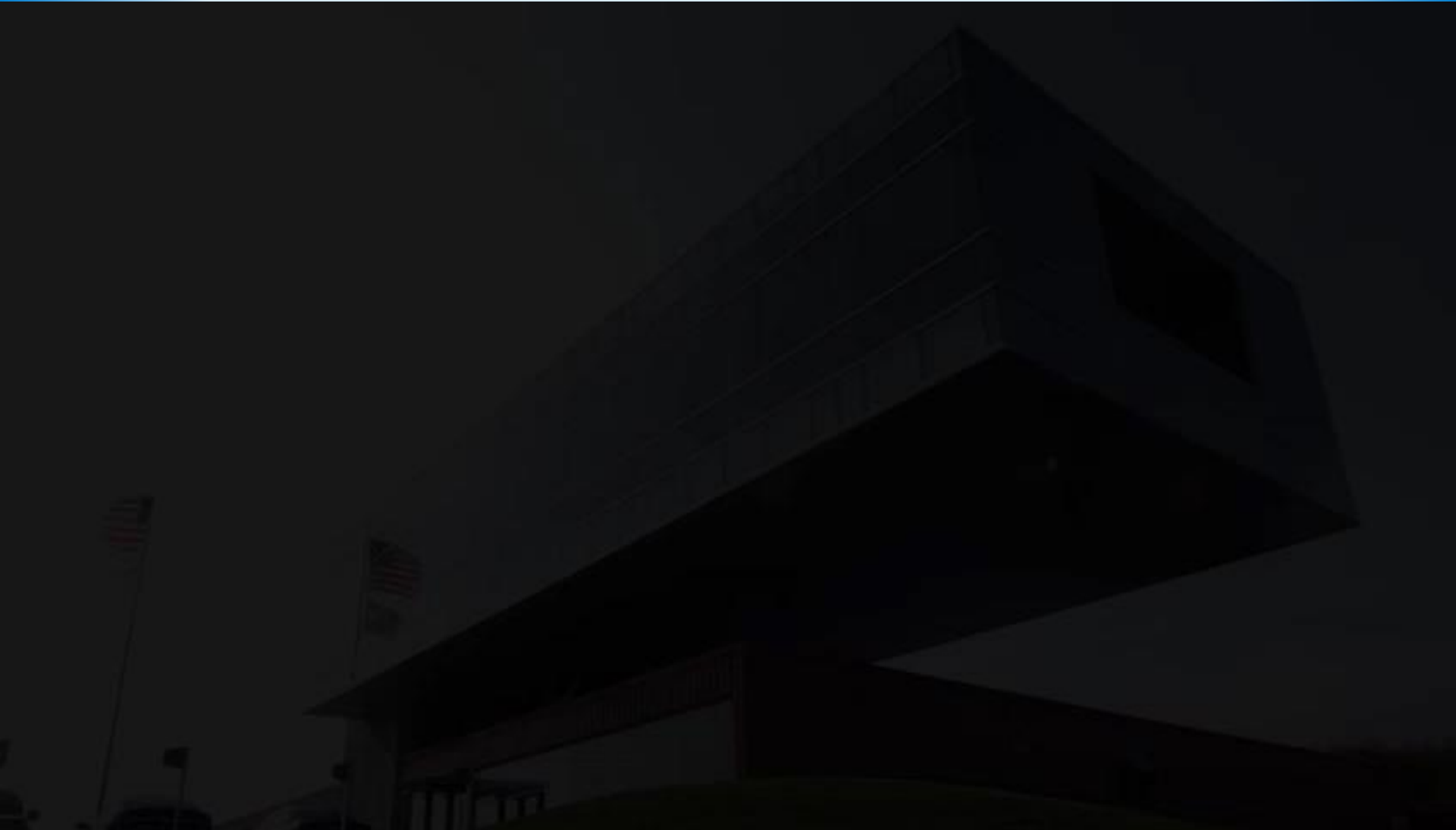

Building Footprint



- 9 Acres
- 47,000 sq. ft.
- 30,000 sq. ft. warehouse
- 69 employees

MFP
AUTOMATION
ENGINEERING



- AUTOMATION
- FLUID POWER
- MANUFACTURING
- ENGINEERING
- HYDRAULICS
- PNEUMATICS
- INSTALLATION
- REPAIRS

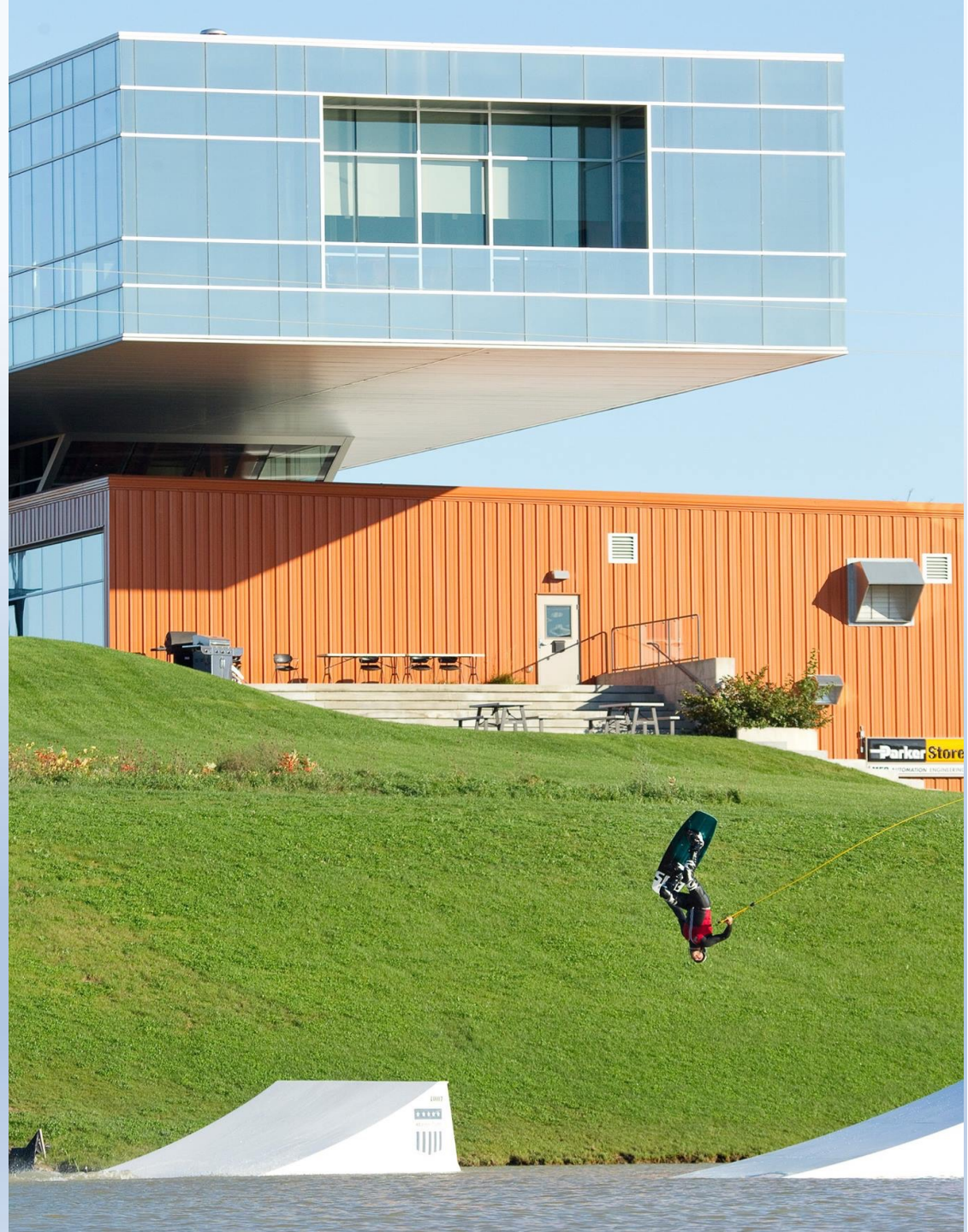

MFP

AUTOMATION
ENGINEERING

INVENTORY CAROUSEL

Up to 80,000 SKUS

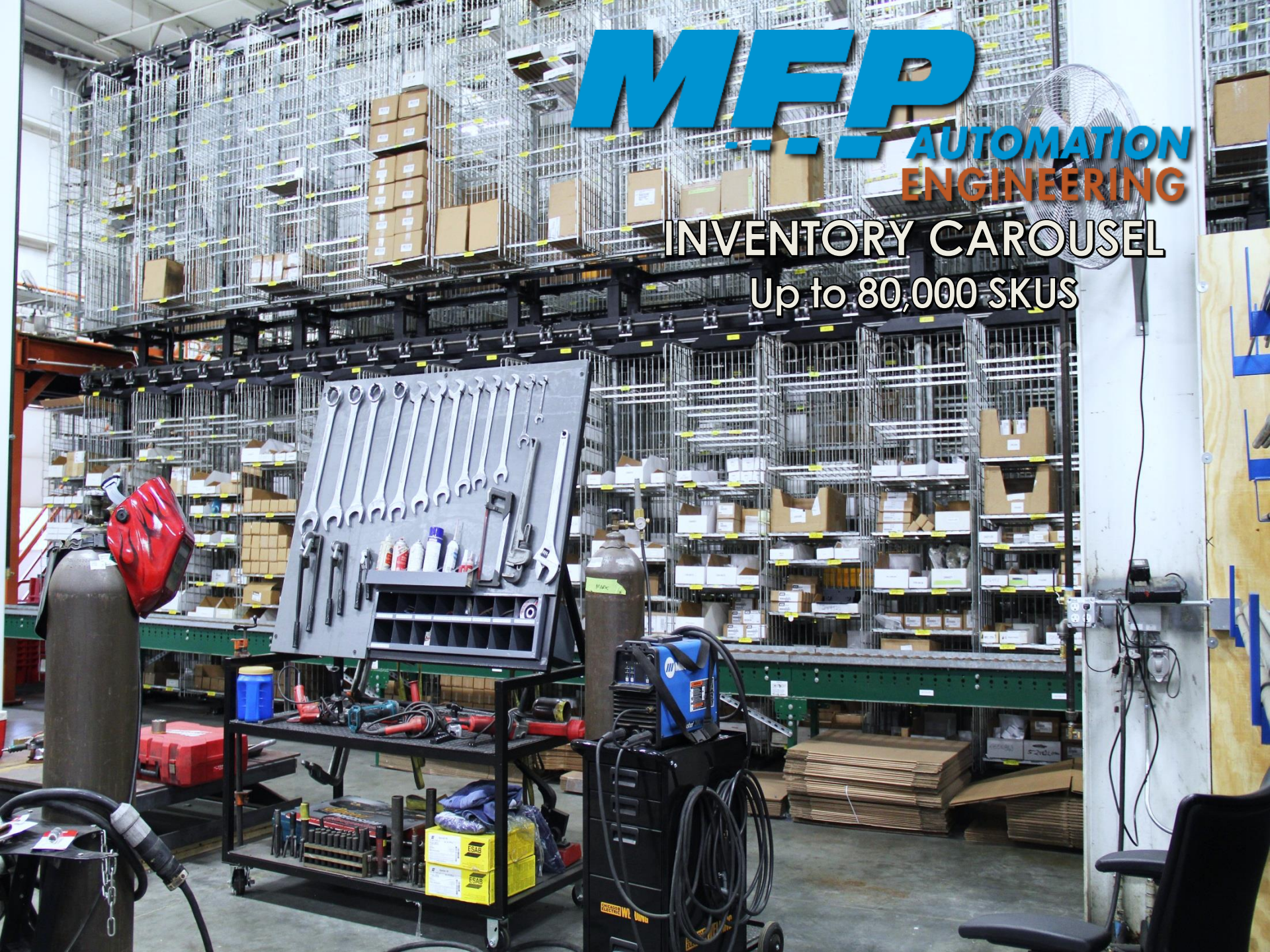

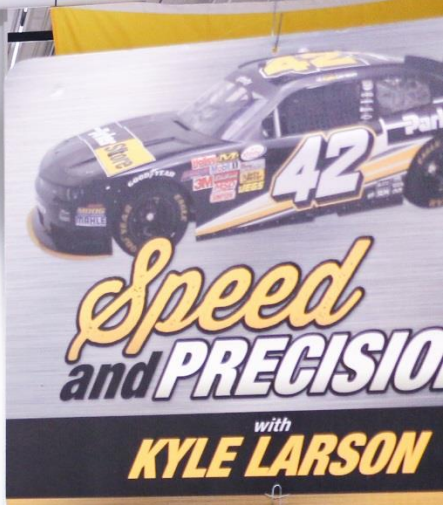

MFP
AUTOMATION
ENGINEERING
LIGHT ASSEMBLY
Hose, Fittings



MFP
AUTOMATION
ENGINEERING

LIGHT ASSEMBLY Hose, Fittings

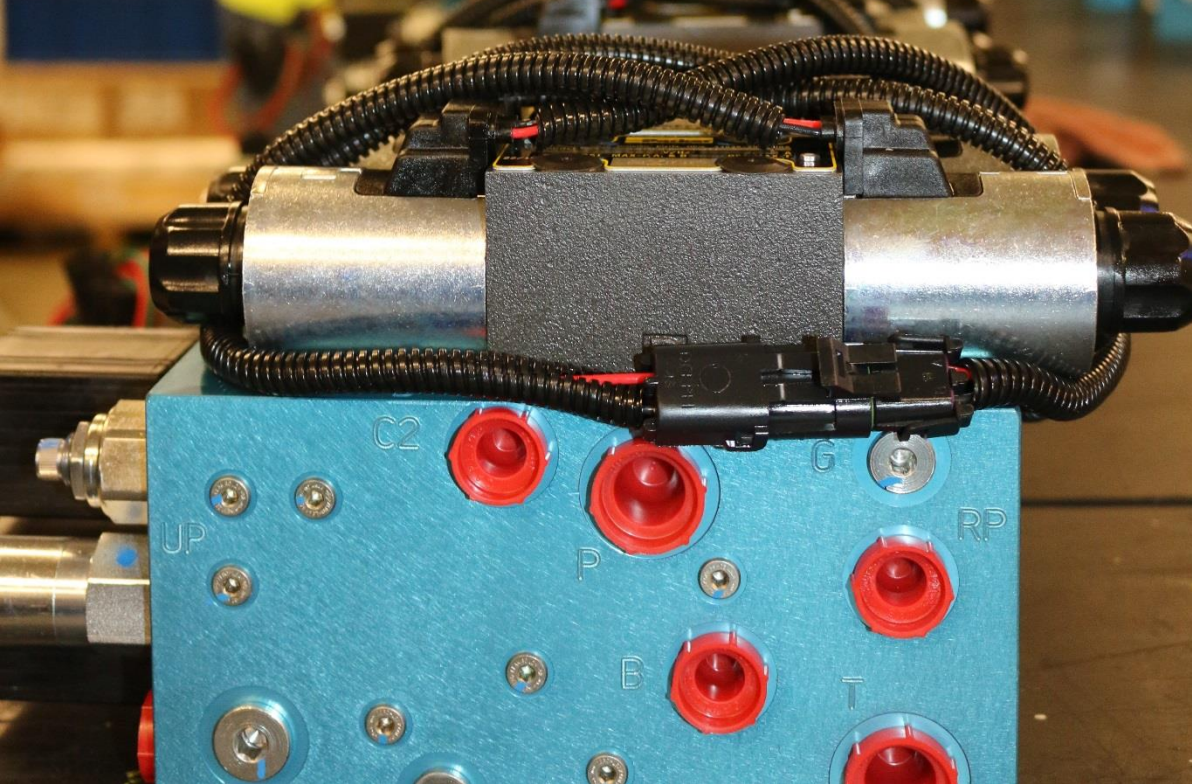
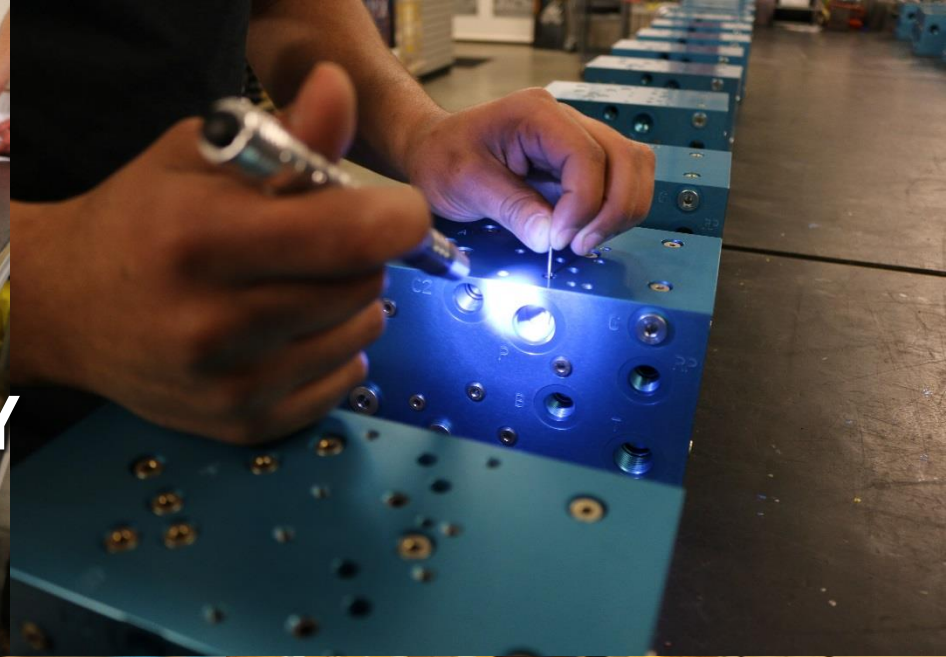

Parker Store

EQUIPMENT RENTAL PROGRAM

Why Rent From ParkerStore?

- Access to the newest technology & equipment
- Test equipment before purchasing
- Flexible rental periods
- Save on maintenance and storage fees
- Individual tooling available



Ask an associate for a list of available rental products today!

MFP
AUTOMATION
ENGINEERING

ON SITE PARKER STORE
Counter Sales Assistance, Hose Assemblies, Fittings, and more!





MFP
AUTOMATION
ENGINEERING

CNC FACILITY

5 CNC machines, 2 Bridgeports
Custom Manifolds & Engineered Solutions

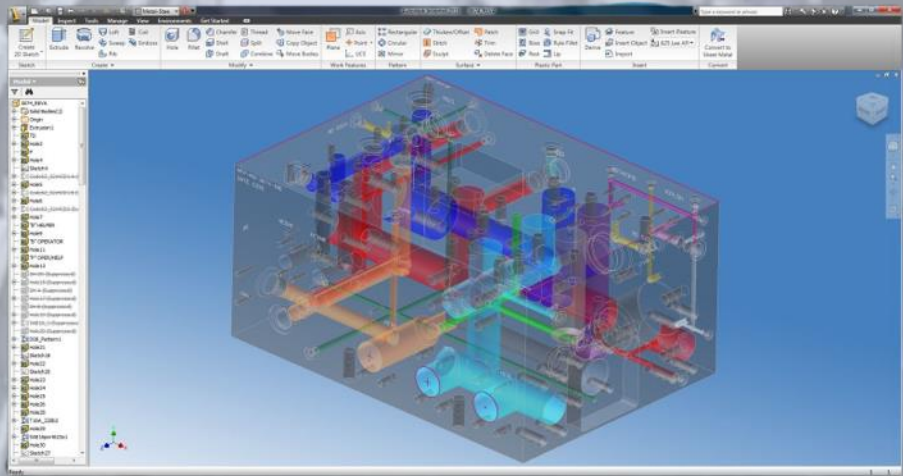
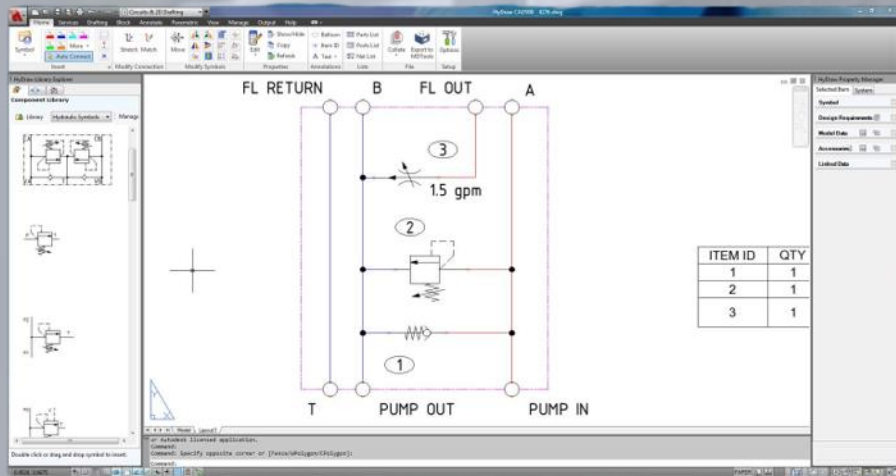
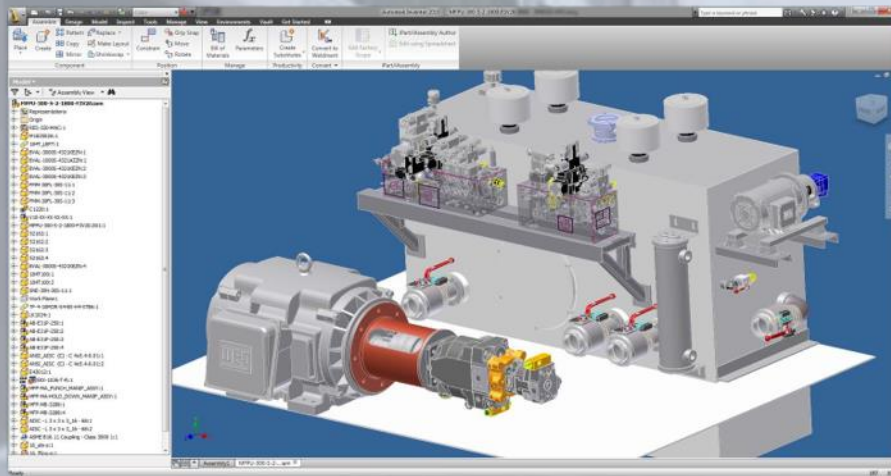

MFP

AUTOMATION
ENGINEERING

ENGINEERING

2D & 3D Design with AutoCAD, SolidWorks, MDTools, and HyDraw Software
 Combined 200+ years of experience

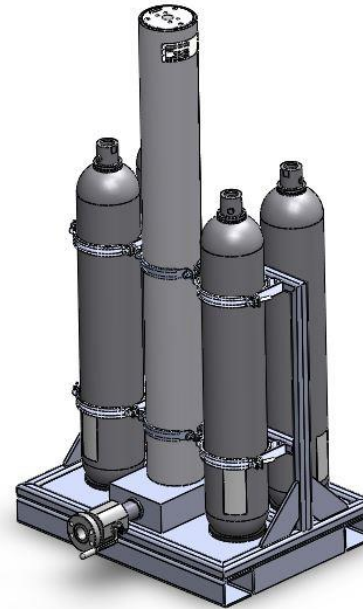
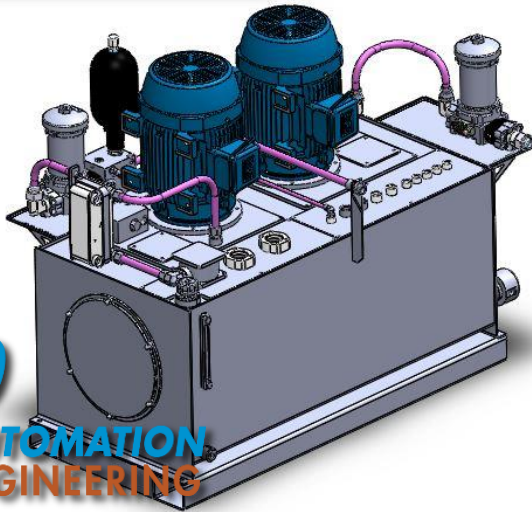
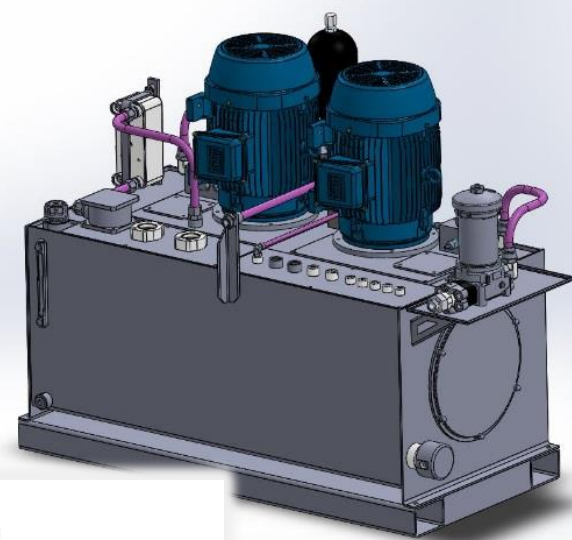
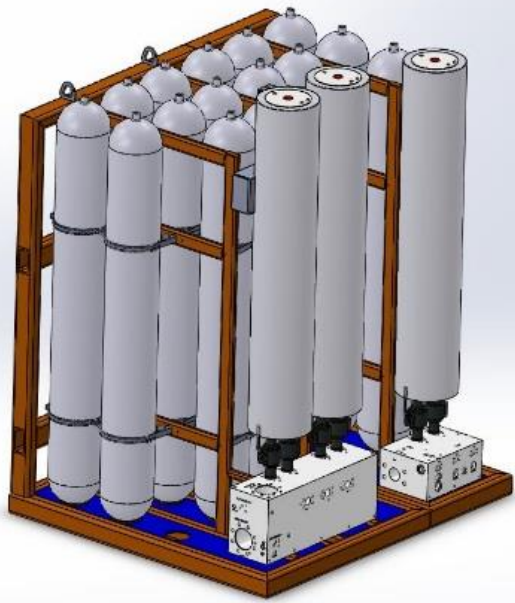

MFP
AUTOMATION
ENGINEERING

ENGINEERING

2D & 3D Design w/ AutoCAD, SolidWorks, MDTools, & HyDraw Software
Combined 200+ years of experience



MFP
AUTOMATION
ENGINEERING

MANUFACTURING
Custom Manifolds & Engineered Solutions



MFP

AUTOMATION
ENGINEERING

MANUFACTURING

Custom Hydraulic Power Units & Systems

BEFORE



AFTER



MFP
AUTOMATION
ENGINEERING

RESTORATION

Custom Hydraulic Power Units & Systems



MFP
AUTOMATION
ENGINEERING

RENTAL EQUIPMENT

Filter Cart, Portable Karrykrimp, Power Unit,
Hydraulic Bender and Electric Flaring Tool, Hydra Tool



MFP
AUTOMATION
ENGINEERING

ELECTROMECHANICAL
Components & Engineered Systems

AUTOMATION Panel Build Assembly





Sensing & Safety

Complete Automation Solutions



Electric



T-Slot Extrusion



Material Handling

Complete Automation Solutions



Pneumatics



Fluid Power



Motion Control



MFP AUTOMATION
ENGINEERING

ELECTRONIC INTEGRATION CENTER



MFP
AUTOMATION
ENGINEERING

MOBILE MACHINE CONTROL
FULL-SYSTEM SOLUTION
Electronic Controls Division

VFD HPU



**STANDARD POWER UNIT
22" x 27" x 40"**



**VFD POWER UNIT
18" x 11" x 30"**

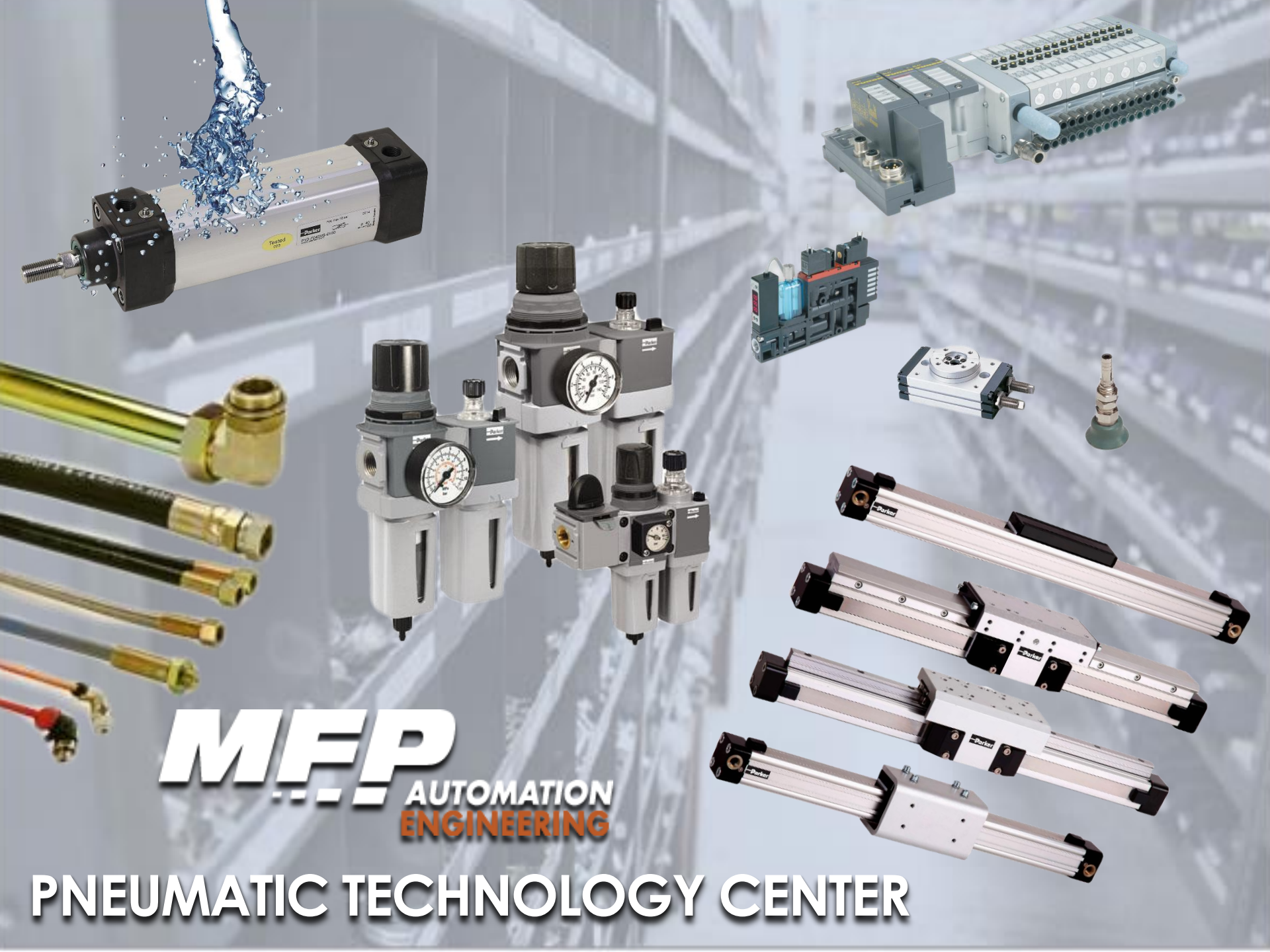

MFP
AUTOMATION
ENGINEERING

PNEUMATIC TECHNOLOGY CENTER

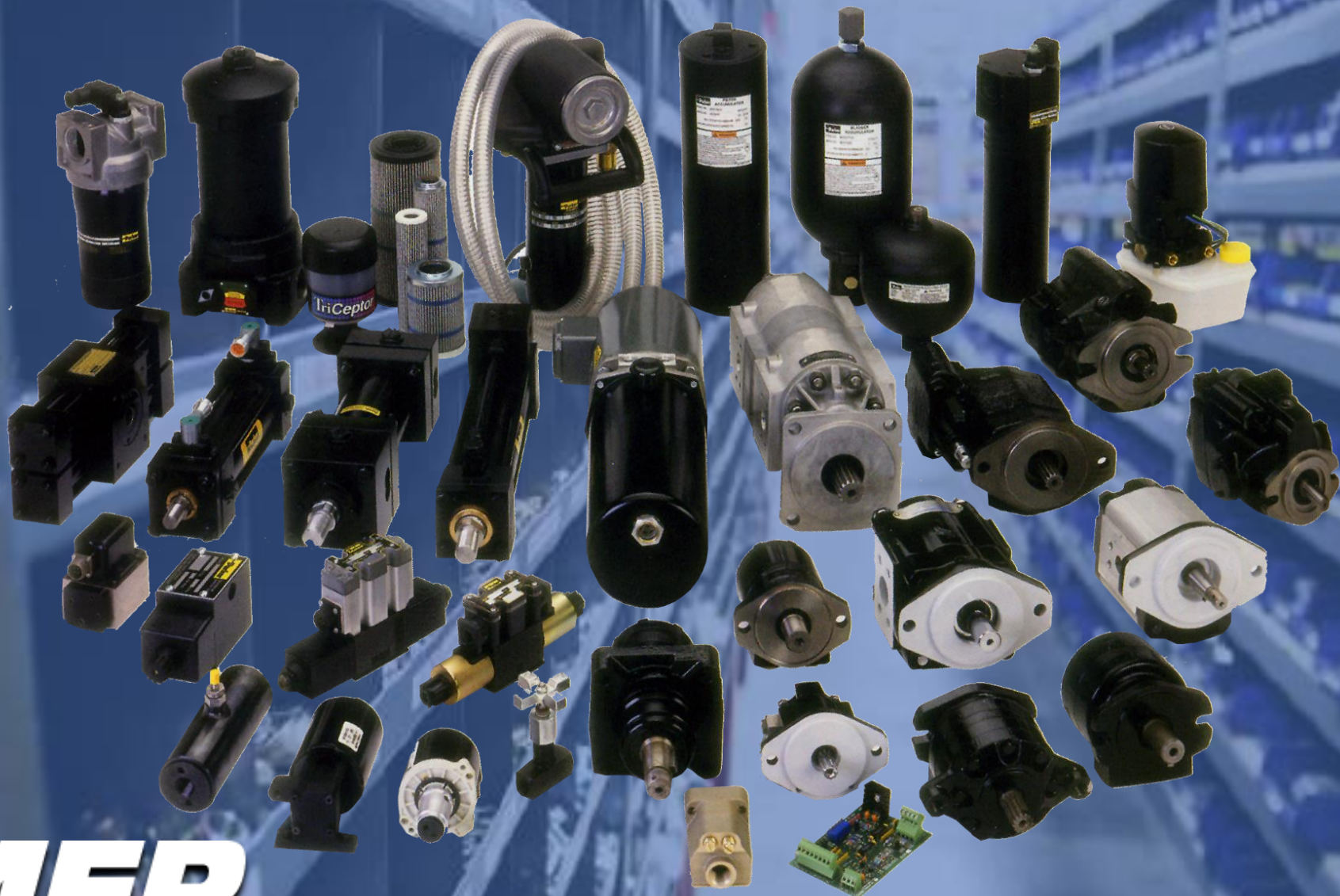

MFP
AUTOMATION
ENGINEERING

HYDRAULIC TECHNOLOGY CENTER

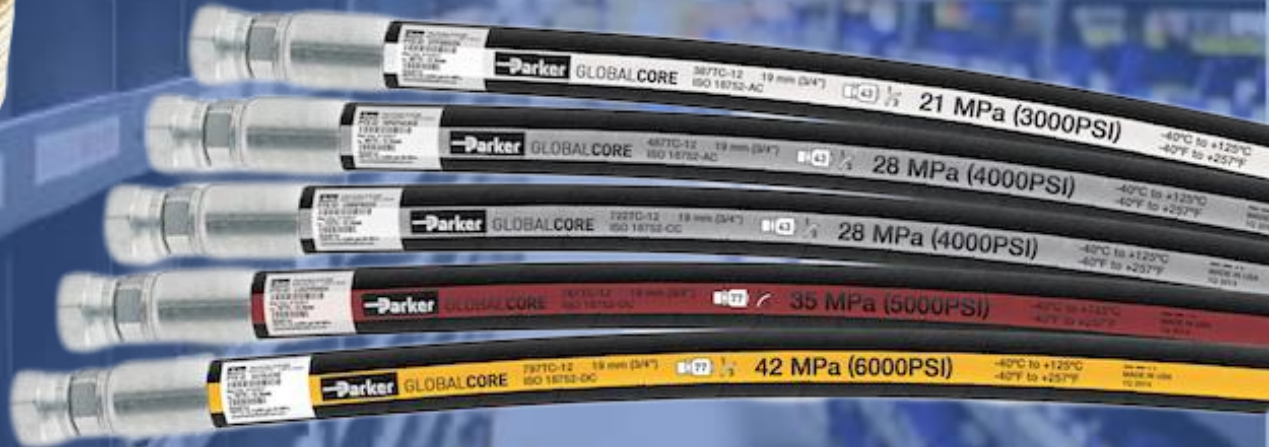

MFP
AUTOMATION
ENGINEERING

FLUID CONNECTORS



MFP

**AUTOMATION
ENGINEERING**

LUBRICATION

Installation, Industrial Automatic
Lubrication, Mobile Chassis



MFP
AUTOMATION
ENGINEERING

LUBRICATION

Service Center Fluid Management Systems,
System Layout Design & Installation



MFP
AUTOMATION
ENGINEERING

**ON-ROAD / MOBILE
LUBRICATION**



ON-SITE SERVICE

Tube Bending, Hose Assemblies, Installation,
Repair Service Contracts, & Fluid Analysis





MFP
AUTOMATION
ENGINEERING

ON-SITE SERVICE

Tube Bending, Hose Assemblies, Installation,
Repair Service Contracts, and Fluid Analysis



MAJOR PROJECTS

**Bridge Job, Alcoa Press,
Parker Test Stand**



MAJOR PROJECTS

DNR Boat



MFP

**AUTOMATION
ENGINEERING**

Questions?

info@mifp.com
www.mifp.com