

Piston pump unit

# Product series KFG

For fluid grease and grease

For use in SKF MonoFlex and SKF ProFlex centralized lubrication systems



## Features:

- Delivery rates: 0.8 to 15 cm<sup>3</sup>/min
- Fluids delivered: Fluid grease and grease
- Reservoir capacities: 2 to 20 kg
- Patented grease follower plate system for position-independent application (e.g. rotary application in wind energy systems)
- Integrated fill level monitoring
- Control unit that can be integrated
- For use in vehicles, Industrial and wind energy systems
- The commercial vehicle version has type approval pursuant to ECE-R 10

## Advantages:

- Reliable: due to sturdy materials, very durable components and designs for extreme conditions (with positively driven pump elements)
- Application-oriented: individual designs through user-friendly product customizer
- Versatile: can be used as a single line (SKF MonoFlex) and as a progressive pump (SKF ProFlex)
- Safe: through fill level monitoring, lubrication system monitoring, pressure relief and control unit



**Important information on product usage**

SKF and Lincoln lubrication systems or their components are not approved for use with gases, liquefied gases, pressurized gases in solution and fluids with a vapor pressure exceeding normal atmospheric pressure (1 013 mbar) by more than 0,5 bar at their maximum permissible temperature.

# KFG piston pump unit

## Table of contents

Product selection table .....	3	Product customizer .....	11
Introduction .....	4	Dimensioned drawings .....	12–13
Fields of application .....	4	Technical data .....	14
Functional description in SKF centralized lubrication systems .....	5	Accessories .....	15–16
Main components .....	6–9	Special designs .....	17
Designs .....	10	Exploded-view and spare parts drawings .....	18
		Wearing parts and spare parts .....	19

## Productselection table

Overview		SKF system family		Field of application			Page
		SKF MonoFlex	SKF ProFlex	Rotary	Industry	Vehicle	
Control unit	Without internal and external control unit	–	•	•	•	•	8
	Internal control unit IG502-2-I	–	•	•	•	•	8
	Internal control unit LC502	•	•	•	•	•	8
Reservoir capacity [kg]	2	•	•	–	•	•	7
	4	•	•	•	–	–	7
	6	•	•	•	•	•	7
	8	•	•	•	–	–	7
	10	•	•	•	•	•	7
	12	•	•	•	–	–	7
	15	•	•	•	•	•	7
	20	•	•	–	•	•	7
Pump element	With positively driven piston	•	•	•	•	•	6
	With spring-return piston	•	•	•	•	•	6
Fill level indicator	None	•	•	•	•	•	7
	With mechanical fill level switch	•	•	–	•	•	7
	With mechanical fill level switch and signal smoothing	•	•	–	•	•	7
	With capacitive proximity switch	•	•	–	•	–	7
	With cylinder switch	•	•	•	–	–	7
Metered quantity	0.8–5 cm <sup>3</sup> /min (per outlet)	•	•	•	•	•	6
Filling	Lubricant nipple	•	•	–	•	•	6
	Socket for filling cylinder	•	•	–	•	•	9
	Filler coupling on reservoir cover	•	•	•	–	–	7
Valves	None	–	•	•	•	•	9
	Relief valve incl. pressure restriction valve	•	–	•	•	•	9
	Pressure restriction valve	–	•	•	•	•	9
Elect. connection	12 V DC	•	•	–	–	•	6
	24 V DC	•	•	•	•	•	6
	230 V AC (90–264 V AC)	•	•	•	•	–	6

# KFG piston pump unit

## Introduction

The KFG pump unit is an electrically driven piston pump. Its core is comprised of a drive shaft with an eccentric that drives up to three pump elements. Various designs make it possible to accommodate this sturdy and proven principle of operation to different circumstances.

The pump is comprised of four main components: Housing with pump elements, reservoir with fill level monitoring, internal control units and attachments. The housing integrates the motor, the drive shaft with an eccentric and up to three pump elements for delivering the lubricant. Positively driven pump elements should be used in order to maintain the delivery rate in areas with extremely low temperatures or in applications where an increased influence of dirt is unavoidable.

The reservoir is used for storage of the lubricant. It is available in eight sizes and two variants for stationary utilization or with grease follower plate technology for utilization in any position. The internal control units monitor the switching on and off of the pump. In addition, they enable the evaluation of piston detector, pressure switch and fill level signals. A variety of attachments permit the filling of the reservoir, protect the pump (pressure limitation valve), relieve the system (only when used in single-line systems) or enable the uncomplicated connection of the pump to the centralized lubrication system.



## Fields of application



### Vehicle

It is particularly with changing operating conditions that vehicles must function reliably. KFG piston pump units are the heart of SKF centralized lubrication systems for vehicles. They supply all of the connected lubrication points in an optimum manner and thus reduce service and repair costs but up to 25%.



### Industry

Friction, e.g. in machine tools, causes great wear and thus wastes valuable natural resources. SKF centralized lubrication systems with KFG pump units reduce friction and thus considerably extend the service life of machine tools, for example.



### Rotary application

Centralized lubrication systems such as SKF WindLub with the KFG pump unit for rotary application reduce the wear on modern wind energy systems and thus ensure a long preservation of value. They shorten the time required for repair and lengthen the repair intervals. That saves money.

# KFG piston pump unit

## Functional description in SKF centralized lubrication systems

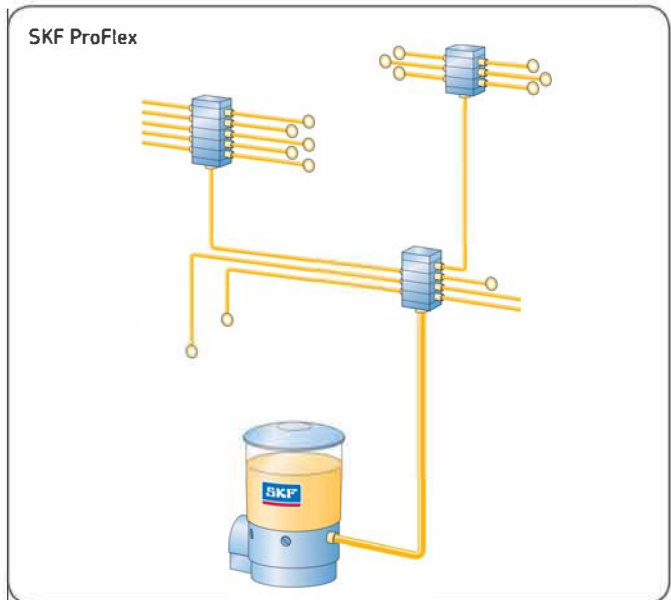
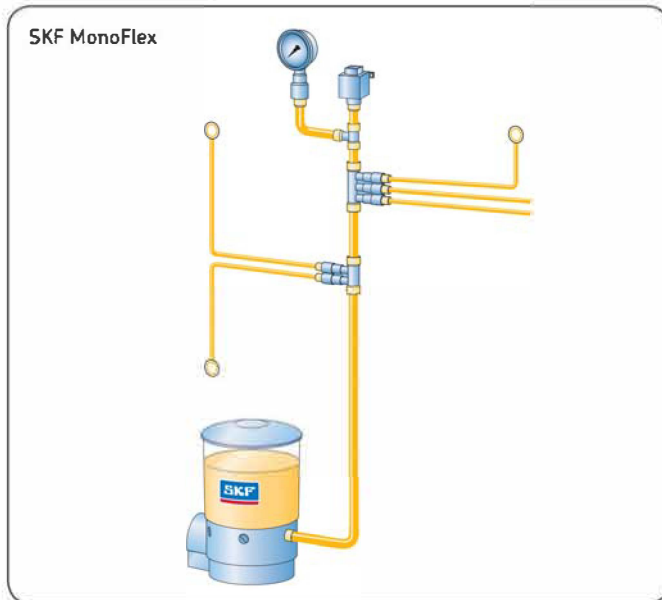

### SKF MonoFlex – Single-line centralized lubrication systems

The SKF MonoFlex System is comprised of:

- Pump unit with pump element(s) and relief valve
- Lubricant lines
- Single-line distributors
- Pressure switch for pump control unit and monitoring

When the pump motor is turned on, the pump element suctions the lubricant out of the reservoir and conveys it through the relief valve to the lubrication line. Through this it flows to the single-line distributors. There it is metered and forwarded to the lubrication points during the pump runtime. Once the pressure build-up is completed, the relief valve, controlled by a pressure switch, switches over. As soon as the main line is relieved of pressure, the system is ready for the next lubrication cycle.

### SKF ProFlex – progressive centralized lubrication systems

The SKF ProFlex System is comprised of:

- Pump unit with pump component(s)
- Lubricant lines
- Progressive feeders
- Optional piston detectors for function monitoring

When the pump motor is turned on, the pump element suctions the lubricant out of the reservoir and conveys it to the lubrication line. Through this it flows to the progressive feeder. There it is divided up, depending on how much lubricant is required at the lubrication points to be supplied.

In progressive systems with master and secondary feeders, the lubricant is first delivered to the master feeder. The master feeder distributes the lubricant to the secondary feeders according to their individual volume requirements. From there, the lubricant flows to the lubrication points. Piston detectors can be connected to the function monitoring. The function monitoring of a lubrication system with the aid of a single piston detector is possible, thanks to the positively driven distribution of the lubricant typical for progressive systems.

# KFG piston pump unit

## Main components

### Pump housing

The housing of the KFG pump unit is made of sturdy aluminum. Integrated within are the electric motor, the power supply unit (only with 230 V AC variant), the drive shaft with eccentric and one to three pump elements. The eccentric converts the rotational movement into a stroke movement of the pump element. The pump element pushes out lubricant during its forward movement and suctions in new lubricant from the lubricant reservoir during its retraction movement.

In the design for the vehicle and industry sector, the lubricant reservoir is filled through a conical head nipple on the pump housing. In addition, two different control units (IG502-2-I and LC502) can be integrated as optional equipment. Their displays are attached in a readily accessible manner to the front side of the pump housing. Basically speaking, the pump unit is available with three voltage keys: 12 V DC, 24 V DC and 230 V AC. KFG pump units with control unit, a 230 V power supply unit or with mechanical fill level switch have a deep bottom (foot). The overall dimensions are changed as a result.



### Pump elements

Pump elements deliver the lubricant to the lubrication points or distributors through lubrication lines. Five pump elements for delivery rates of from 0.8 to 5.0 cm<sup>3</sup>/min are available for selection in two designs:

- with spring-return piston
- with positively driven piston

In many application instances, the pump element with spring-return piston is the correct choice. The pump element with positively driven piston was developed for use in extremely cold environments (to -30 °C).

or for high-viscosity lubricants. Up to three pump elements can be installed in the KFG pump unit. The possible attachment positions are located on the left (1), at the front (2) and on the right (3) on the pump housing. The lubricant outlet on the pump element has an M14x1.5 female thread for connecting lubrication lines or valves. If no pump element is installed, then the outlet of the pump housing is sealed with a screw.

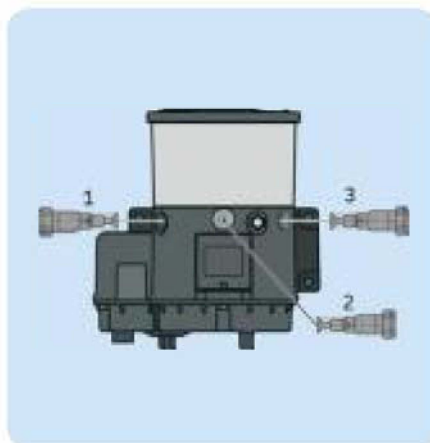

#### Note

If more than one pump element is installed in a KFG pump unit for an SKF MonoFlex system, then their outlets will be consolidated externally to form one main lubrication line. The total delivery rate is then derived from the sum of the respective delivery rates of the individual pump elements.

#### Marking of the pump elements

Model	Spring-return	Positively driven
Delivery rate* [cm <sup>3</sup> /min]	Number of the marking grooves on the head of the pump element	Labeling
0,8	4	-
1,3	3	J-3
1,8	2	H-2
2,5	1	G-1
5,0	0	L-0

\* The specified quantities refer to grease of NLGI class 2 at 20 °C and a back pressure of 50 bar.

# KFG piston pump unit

## Main components

### Reservoir

Two different reservoir types exist for the KFG pump unit: one for stationary and one for rotary application. A grease follower plate system patented by SVK is to be found in the lubricant reservoir of the units for rotary application. A spiral spring assembly is attached to the grease follower plate. This presses the follower plate onto the lubricant. As a result, the lubricant is always available at the pump element, independent of the position of the unit. The filling of this reservoir variant is carried out through a quick-action coupling on the reservoir cover in accordance with the "First In - First Out" principle. This avoids having old grease in the lubricant reservoir. The initial filling of the reservoir is made by SKF. In the reservoirs without grease follower plate technology, for industry and vehicle applications, the lubricant is worked by an agitator. This avoids air pockets and improves pumpability.

### Fill level monitoring through mechanical fill level switches

The mechanical fill level switches are mounted on the agitator. The grease resistance causes them to pivot downwards when the reservoir is filled and the agitators rotate. When the minimum fill level is reached, the pressure of the grease is reduced to the rocker switch.

### Fill level monitoring through capacitive proximity switches

Capacitive proximity switches are contact-free sensors that react with an electrical switching signal when a medium approaches.

### Fill level monitoring using cylinder switches

In the case of cylinder switches, contactless solenoid switches are used. They measure the change of the magnetic field and convert this into a digital signal. In the case of the KFG pump, they are used solely in units that have a grease follower plate.

The filling of the variants without grease follower plate technology takes place through the housing, as is described on page 6. Reservoir capacities of from 2 to 20 kg are available for vehicles and industrial plants and reservoir capacities of from 4 to 15 kg for rotary applications.

Depending on the field of application, three variants exist for monitoring the fill level in the lubricant reservoir: capacitive proximity switches, mechanical fill level switches and cylinder switches.

Cylinder switches are suitable for the reservoir model with grease follower plate. The capacitive proximity switch is suitable for stationary application with grease and fluid grease of the NLGI classes 1, 0, 00, and 000. The mechanical fill level switch is to be used for the stationary application with grease of NLGI class 2.

It pivots back and thus interrupts the contact to the solenoid switch. The mechanical fill level switches are used only in stationary KFG units for fill level monitoring of the lubricating medium of NLGI class 2 grease. A version with signal smoothing is also available for the evaluation of the signal with external control units.

They are used in KFG pump units for minimum fill level monitoring of the lubricating medium fluid grease and grease up to NLGI class 1.

When several cylinder switches are used various switching points such as Minimum, Maximum of Fill level pre-warnings can be monitored by the detection of the position of the grease follower plate.



# KFG piston pump unit

## Main components

### Internal control unit IG502-2-I

The control unit IG502-2-I with control display can be integrated in the pump housing and controls the turning on and off of the KFG pump by means of interval times and pump runtimes. It enables the fill level monitoring of the lubricant reservoir and the evaluation of a piston detector signal (setting of the control unit when a signal is expected from the piston detector during the runtimes: COP=CS). It is suitable exclusively for the monitoring of SKF ProFlex systems.

**Note**  
Legend of the abbreviations for the programming of the control units:

- COP:** Cycle Off Pressure (main line pressure off)
- PS:** Pressure-Switch (pressure switch)
- CS:** Cycle-Switch (piston detector)



### Internal control unit LC502

The control unit LC502 offers the same range of functions as the IG502-2-I. In addition, it enables the control of single-line systems (SKF MonoFlex) through the evaluation of a pressure switch signal (setting of the control unit, if a signal is expected from the pressure switch during the runtimes): COP=PS).

With the LC502, it is possible to monitor two piston detectors in progressive systems (SKF ProFlex) simultaneously. (Setting of the control unit, if a signal is expected from the piston detector during the runtimes: COP=CS.)



### Pump runtimes and interval times

In the control device Pump run-and pause times can be preset from factory. To make this possible a corresponding code letter

from the following table has to be entered in the order code on page 11.

#### Runtimes IG502-2-I/LC502

Pump runtime * [min]	Letter
2	A
2,5	B
3	C
3,5	D
4	E
4,5	F
5	G
5,5	H
6	I
6,5	J
7	K
7,5	L
8	M
8,5	N
9	O
9,5	P
10	Q
11	R
12	S
13	T
14	U
15	V
16	W
17	X
18	Y
20	Z

\* further pump runtimes on request

#### Interval times IG502-2-I/LC502

Pump pause time * [h]	Letter for control unit without monitoring	Letter for control unit with monitoring
0,5	A	N
1	B	O
1,5	C	P
2	D	Q
2,5	E	R
3	F	S
3,5	G	T
4	H	U
5	I	V
6	J	W
7	K	X
8	L	Y
9	M	Z

\* further pump pause times on request

**Note**  
If during the pump runtime neither a pressure switch nor a piston detector signal is expected, then the control unit should be set as follows: COP=off.  
If a pressure switch signal is expected, then the control unit should be set as follows: COP=PS.  
If a piston detector signal is expected, then the control unit should be set as follows: COP=CS.



# KFG piston pump unit

## Main components

### Pressure restriction valve

In order to prevent an excessive operating pressure in the system, a pivoted pressure restriction valve should be attached. If the operating pressure exceeds the cracking pressure of the pressure restriction valve, then the valve will open and the lubricant can escape. The pressure restriction valve is used primarily in progressive systems. One can select among variants with SKF plug connectors, straight connector and with G 1/4" female thread.

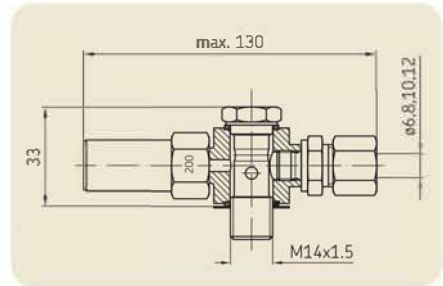

### Pressure relief valve with integrated pressure restriction valve

The valve offers both a pressure regulating and a pressure relief function. SKF MonoFlex systems require pressure relief for the system in order to conclude the metering of the distributors and thus to enable a new lubrication cycle. The pressure regulating function protects the system against excessive operating pressure. This valve is therefore used exclusively in single-line systems. One can select among variants with SKF plug connectors, straight connector and adapter for G 1/4" female thread.

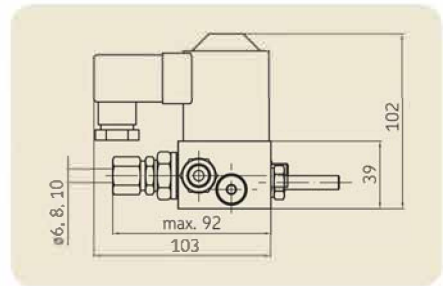

### Socket for filling cylinder

For industry and vehicle applications, one of the three lubricant outlets of the pump can, as an option, be equipped with one suitable filler socket instead of with one pump element, in order to fill the unit using a filling cylinder (cartridge).

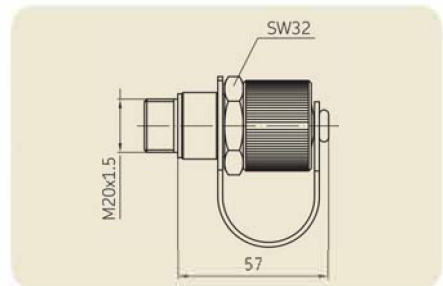

### Fittings

A variety of different fittings with the male thread M14x1.5 are available for selection for the connection of the pump element to the lubrication lines of the centralized lubrication system. One can select among cross sections 6, 8, 10 and 12 mm in size.

If a G 1/4" connection is required, then a special adapter must be used. Additional information regarding fittings and accessories are to be found in the leaflet 1-0103-EN.



Straight connector

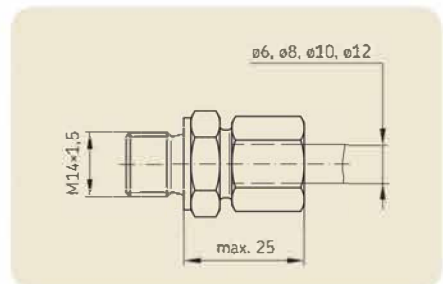

Adapter

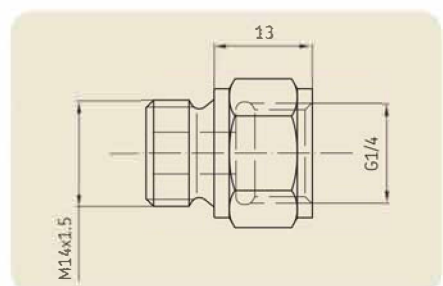

# KFG piston pump unit

## Designs

Control unit IG502-2-1



LC 502 Control Unit



Fitting  
SKF plug  
connector



Fitting  
Cutting-sleeve  
screw union with  
sealing ring



Pressure restriction valve  
for progressive systems  
(SKF ProFlex)



Pressure relief valve with integrated  
pressure restriction valve for  
single-line systems  
(SKF MonoFlex)



KFG unit  
for Industry/Vehicle applications



KFG with grease follower plate technology  
for rotary application  
(e.g. wind energy systems)



Pump element  
(spring-return)



Pump element  
(positively driven)



**Note** This page shows possible designs of the KFG units.

Not all components can be combined with one another. The configurator on the following page allows the functional specification of a KFG reservoir pump unit.

Fill level monitoring  
(mechan. switch for grease, NLGI class 2)



Fill level monitoring  
(capacitive proximity switch for fluid grease, NLGI classes 1, 0, 00, 000)



Fill level monitoring  
(cylinder switch for rotary application)



### Order example

- KFGS3FXXAXXDEB+924**
- KFG piston pump unit
  - IG502-2-1 Control Unit
  - Reservoir capacity 6 kg
  - Vehicle application
  - Without lubricant filling
  - Without fill level monitoring
  - 2.5 cm<sup>3</sup>/min delivery rate of the pump element with spring-return pistons at outlet 1
  - 8 mm fitting at the outlet
  - Factory setting of the control unit
  - System voltage 24 V DC

# KFG piston pump unit

## Product customizer

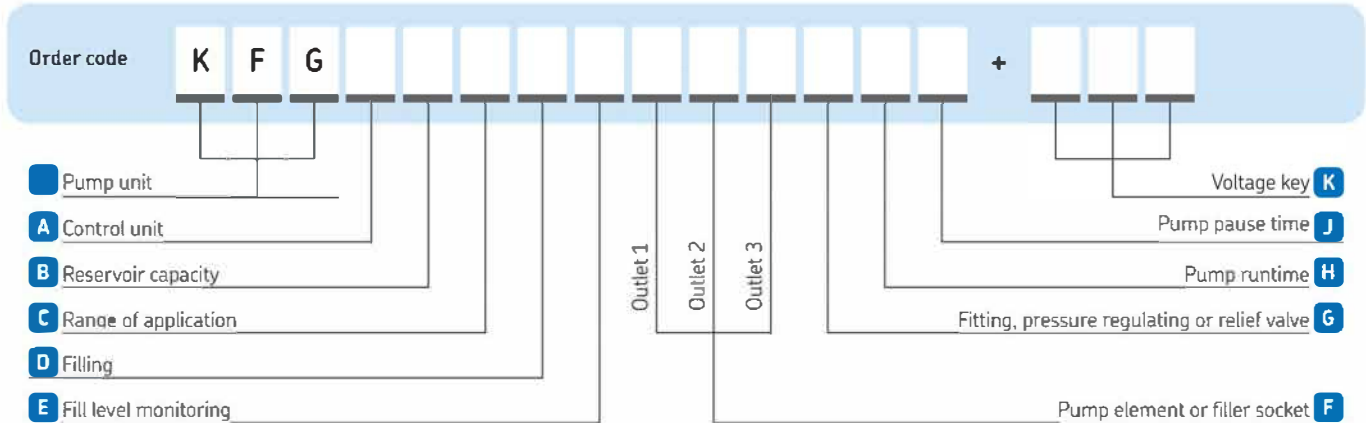

Control unit		System family open	SKF ProFlex	SKF MonoFlex
<b>A</b>	Design			
	None control unit	X	X	X
	IG502-2-I	S	S	-
	LC 502	-	L	L

Pump element / Filler socket		Spring-return piston	Positively driven piston
<b>F</b>	Design		
	without pump element	X	Y
	0,8 cm <sup>3</sup> /min	D	-
	1,3 cm <sup>3</sup> /min	C	J
	1,8 cm <sup>3</sup> /min	B	H
	2,5 cm <sup>3</sup> /min	A	G
	5,0 cm <sup>3</sup> /min	E	L
	socket for filling cylinder (not for rotary application)	W	V

Pump cycle time / Interval time		Control unit	none	IG502-2-I/LC502
<b>H</b>	Runtime <sup>1)</sup>		9	E (4 min)
<b>J</b>	Interval time <sup>1)</sup>		9	B (1 h)

Reservoir capacity, field of application, lubricant filling fill level monitoring and voltage key		Range of application	Rotary	Industry	Vehicle
<b>C</b>			R	M	F
<b>B</b>	2 kg	-		1	1
	4 kg	2		-	-
	6 kg	3		3	3
	8 kg	4		-	-
	10 kg	5		5	5
	12 kg	6		-	-
	15 kg	7		7	7
<b>D</b>	20 kg	-		8	8
	without lubricant	-		X	X
	grease NLGI-Klasse 2 <sup>2)</sup>	A		A	A
	customized grease	F		F	F
<b>E</b>	without fill level monitoring	X		X	X
	mechanically (minimum)	-		1	1
	mechanically with signal smoothing (minimum) <sup>3)</sup>	-		2	2
	capacitive (minimum)	-		3 <sup>4)</sup>	-
<b>K</b>	cylinder switch	4		-	-
	12 V DC	-		-	912
	24 V DC	924		924	924
	230 V AC (90-264 V AC)	486		486	-

<sup>2)</sup> Typical grease for vehicle lubrication, not for capacitive fill level monitoring (3)  
<sup>3)</sup> Possible only with the variant without control unit (KFGX)  
<sup>4)</sup> Possible only in combination the reservoir capacities 2 kg and 6 kg

Fitting, pressure restriction valve (PRV) and relief valve <sup>5)</sup> for attachment to the pump element		Systemfamily	SKF ProFlex	SKF ProFlex	SKF ProFlex	SKF ProFlex	SKF ProFlex	SKF ProFlex	SKF MonoFlex <sup>6)</sup>	SKF MonoFlex <sup>6)</sup>
<b>G</b>	Design		Without attachments	With straight connector	PRV 200 bar with straight connector	PRV 200 bar with SKF plug connector	PRV 300 bar with straight connector <sup>7)</sup>	PRV 300 bar with SKF plug connector <sup>7)</sup>	Pressure relief valve with PLV 200 bar and straight connector	Pressure relief valve with PRV 200 bar and SKF plug connector
	M14x1,5 <sup>8)</sup>	X	-	-	-	-	-	-	-	-
	G 1/4" <sup>8)</sup>	B	-	-	-	-	G	-	W	-
	6 mm	-	C	-	-	-	H	F	-	S
	8 mm	-	D	M	P	-	J	L	V	T
	10 mm	-	E	N	-	-	K	-	U	-
	12 mm	-	-	O	-	-	-	-	-	-

<sup>5)</sup> For technical reasons, the first pump element must always be installed at Outlet 1 in SKF MonoFlex systems.  
<sup>6)</sup> If the relief valve is configured together with several pump elements, then the lines leading from the pump elements will be joined together ahead of the relief valve.  
<sup>7)</sup> Not possible in combination with the pump elements E and L.  
<sup>8)</sup> Female thread

PUB LS/P2 12649 EN:1-3030-EN

# KFG piston pump unit

## Dimensioned drawings



### Important note

Starting with a reservoir filling capacity of 10 kg, the only fastening permitted is with the retaining ring on the reservoir.

**KFG unit without deep bottom**  
(for vehicle and industrial applications)

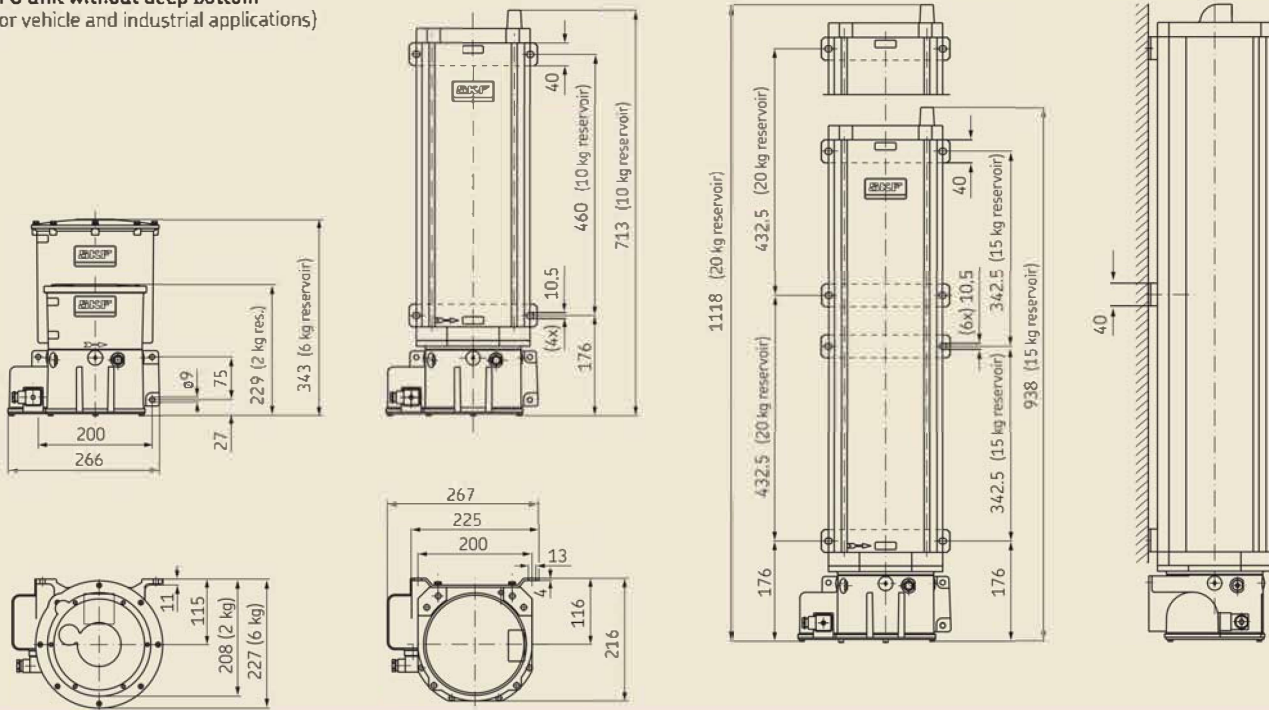

**KFG unit with deep bottom**  
(for vehicle and industrial applications)

Design with deep bottom, if:

- Fill level monitoring Model 1 or 2
- or voltage key 486
- or control unit Model S or L

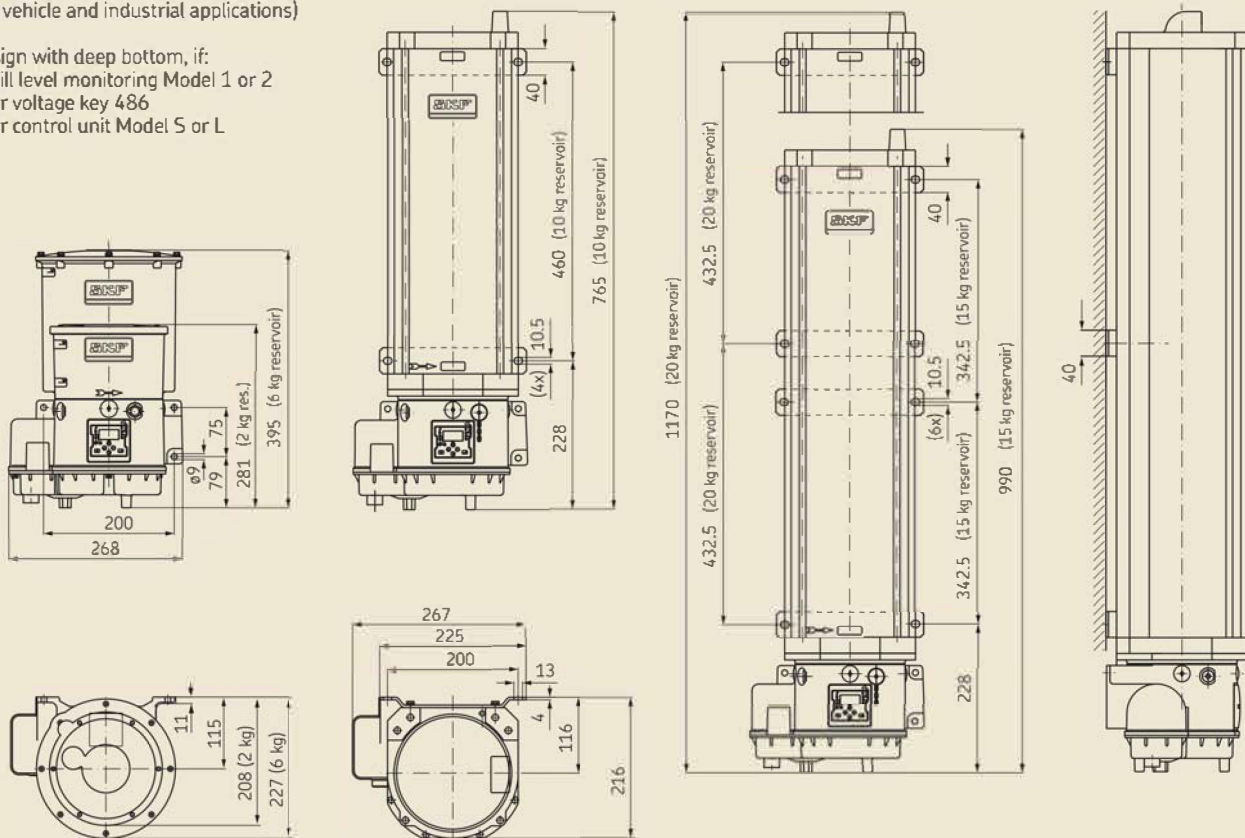

# KFG piston pump unit

## Dimensioned drawings



### Important note

Starting with a reservoir filling capacity of 10 kg, the only fastening permitted is with the retaining ring on the reservoir.

**KFG unit without deep bottom**  
(for rotary application)

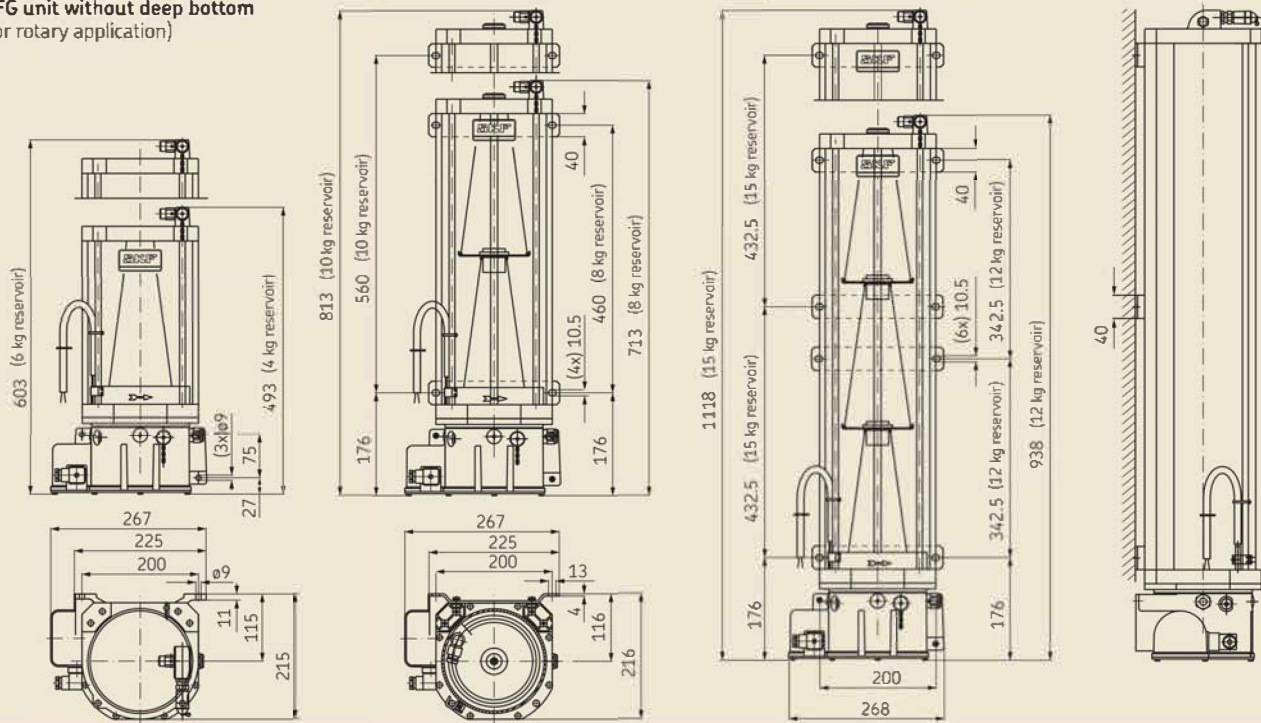

**KFG unit with deep bottom**  
(for rotary application)

Design with deep bottom, if:  
 - voltage key 486  
 - or control unit Model S or L

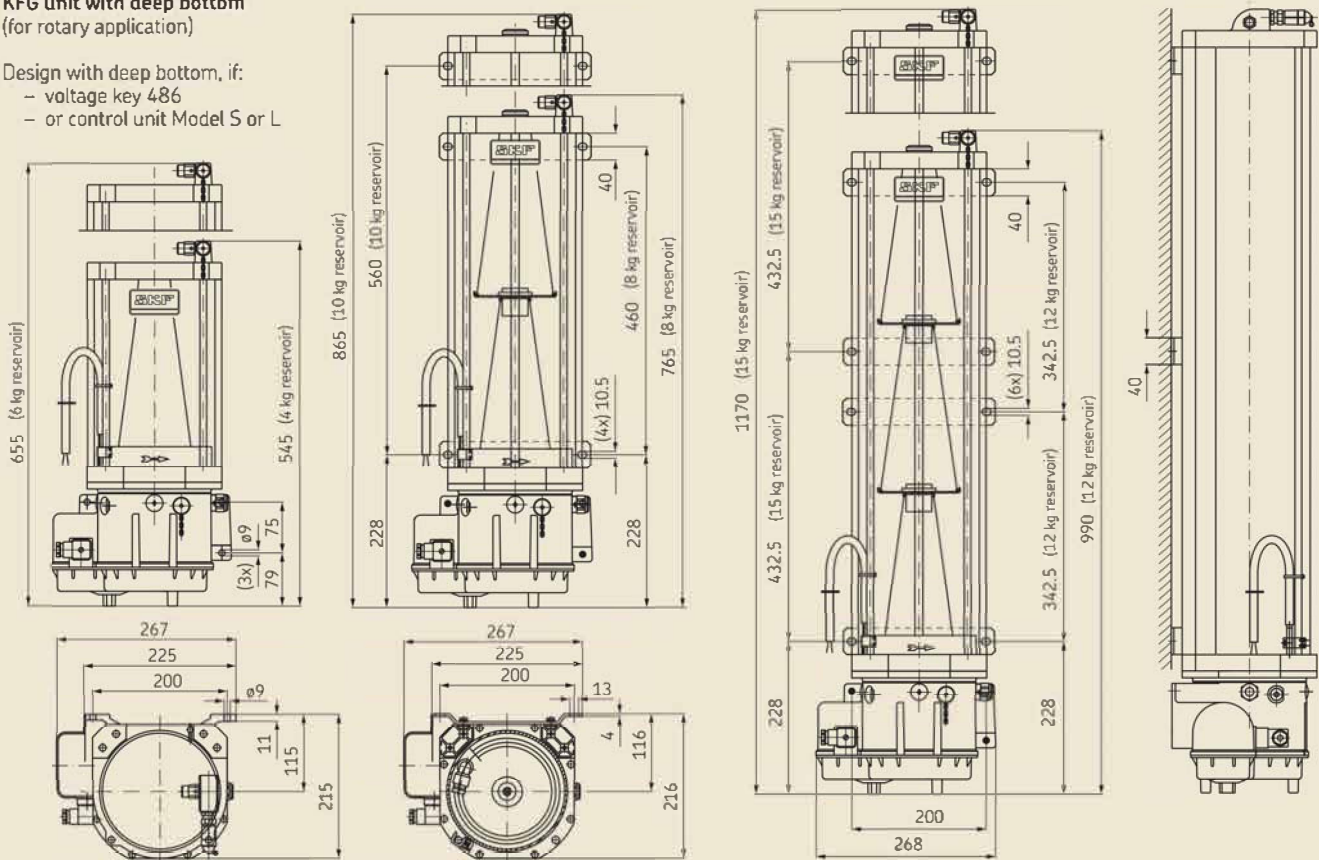

# KFG piston pump unit

## Technical data

### General information

Operating temperature:  
spring-return pump elements  
(for 115/230 V AC only to +60 °C), . . . . . -25 to +70 °C

Positively driven pump elements  
(for 115/230 V AC only to +60 °C), . . . . . -30 to +70 °C

Lubricant . . . . . NLGI Grades 000 to 2 with  
EP additives, compatible  
with plastics, NBR  
elastomers, copper and  
copper alloys

Flow pressure . . . . . up to max. 700 mbar  
(Pump elements from 0.8–2.5 cm<sup>3</sup>/min)

Flow pressure . . . . . up to max. 450 mbar  
(Pump elements with 5.0 cm<sup>3</sup>/min)

Protection class according to DIN 40050, T9IP56

### Weight empty of the pump without attachments

Rotary application		Stationary application	
Reservoir capacity	Weight empty	Reservoir capacity	Weight empty
4 kg	11 kg	2 kg	6 kg
6 kg	12 kg	6 kg	7 kg
8 kg	14 kg	10 kg	14 kg
10 kg	15 kg	15 kg	16 kg
12 kg	17 kg	20 kg	18 kg
15 kg	18 kg		

### Pump housing and reservoir

Pump housing material . . . . Aluminum-silicon cast alloy

Reservoir material:  
2, 6 kg . . . . . Polyamide PA 6I  
4, 8, 10, 12, 15, 20 kg . . . . PMMA

System voltage . . . . . 12 V DC, 24 V DC, 230 V AC (90–264 V AC)

Connector plug Variant . . . . - 7-pin circular plug  
- 12-pin elbow connector M16x0.75  
- 4-pin circular plug/socket M12x1  
(IEC 60947-5-2 cable socket)  
- 4-pin square connector  
(DIN EN 175301-803 cable socket)

Operating mode/ON-time according to VDE0530/DIN 41756  
With 12/24 V DC . . . . . S1 (continuous duty, constant loading)

With 115/230 V AC . . . . . S1 (continuous duty, constant loading)  
and -30 to +40 °C . . . . . Minimum runtime 0 to 10 min Interval  
time = 4 x runtime (20% ON-time)

With 115/230 V AC . . . . . Runtime 10 to 15 min  
and 40 to 60 °C . . . . . Minimum interval time = 2 h

### General conditions for electrical connections

Rated voltage	Power consumption <sup>1)</sup>	Power consumption (max)	Pump starting current (approx. 20 ms)	Maximum back-up fuse for industrial and rotary application	Maximum back-up fuse for vehicle application <sup>2)</sup>
12 V DC	2.4 A	< 5 A	9 A	—	5 AT
24 V DC	1.25 A	< 2.5 A	4.5 A	4 AT	3 AT
115 V AC	K.A.	1.5 A	20 A	C6A <sup>3)</sup>	—
230 V AC	K.A.	0.9 A	40 A	C6A <sup>3)</sup>	—

<sup>1)</sup> Typical values for an ambient temperature of approx. 25 °C and an operating pressure of 150 bar (load-dependent)

<sup>2)</sup> Fuse protection in accordance with DIN72581 T3

<sup>3)</sup> Fuse protection of the characteristic C

### Pump elements

Delivery rate:  
Spring-return pump element . . . . . 0.8; 1.3; 1.8; 2.5; 5.0 cm<sup>3</sup>/min

Positively driven pump element . . . . . 1.3; 1.8; 2.5; 5.0 cm<sup>3</sup>/min

Maximum back pressure:  
Spring-return pump element . . . . . 300 bar (200 bar for pump  
element with 5.0 cm<sup>3</sup>/min)

Positively driven pump element . . . . . 350 bar (250 bar for pump  
element with 5.0 cm<sup>3</sup>/min)

### Fill level switch

	Capacitive proximity switches	Mechanical fill level switch	Mechan. fill level switch with signal smoothing	Cylinder switch
Max. switched voltage	10–30 V DC	24 V DC	30 V DC	1–48 V AC/DC
Max. switched current	200 mA	25 mA	n.s.	0.5 A
Max. switching capacity	n.s.	0.6 W	60 W	5 W
Type of contact	NO-contact	NO-contact	Changeover	Changeover
Connection: for KFG with- out control unit	4-pin circular plug M12x1	4-pin circular plug M12x1 (Industry)	4-pin circular socket M12x1 (Industry)	Square connector <sup>4)</sup>
		7-pin circular plug (Vehicle)	7-pin circular plug (Vehicle)	
for KFG with control unit	Internal connection	Internal connection	—	Internal connection <sup>5)</sup>
Internal power consumption	6–12 mA	—	—	—
Voltage drop	≤ 1.8 V	—	—	—

<sup>4)</sup> Cable socket according to DIN EN 175301-803

<sup>5)</sup> Only for use with the IG502-2-I or the LC502 230 V;  
when using the LC502 24 V, the connection is a 4-pin circular connector M12x1

# KFG piston pump unit

## Accessories

### Filler coupling

As an alternative to a conical head nipple, the units for industrial or vehicle applications can also be equipped with a filler socket in order to fill it with a filling pump, e.g. the manual drum pump. A corresponding coupling socket and a hose socket must be mounted on the filling pump.

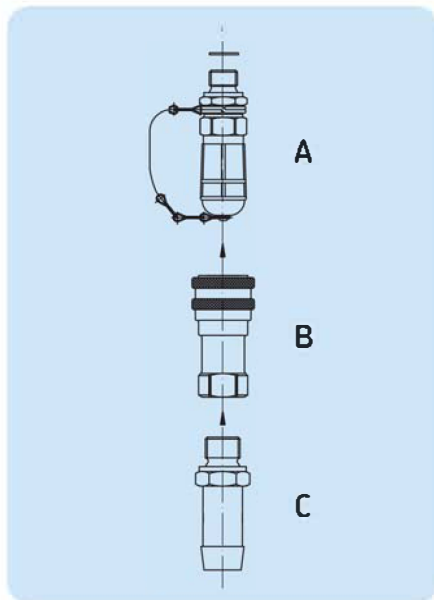

Filler socket



Filling coupling Part A

Description	Order number
Filler socket with sealing ring	24-9909-0244

Coupling socket



Filler coupling Part B

Description	Order number
Coupling socket	995-001-500

Hose socket



Filler coupling Part C

Description	Order number
Hose socket: ø13 mm	857-760-007
ø16 mm	857-870-002

### Filling cylinder

For industry and vehicle applications, a filling cylinder can also be optionally used to fill the pump unit through one of the lubricant outlets. To accomplish this, a filler socket must be configured in the order code in place of a lubricant outlet.



Filling cylinder

Description	Order number
Filling cylinder (socket for filling cylinder w must be configured on KFG pump in the order code on page 11)	169-000-171

### Manual drum pump

The manual drum pump is for simple filling-up of the KFG piston pump unit. It is available in the designs with and without trolley and is suitable for NLGI class 1 and 2 greases. The delivery rate of the drum pump is approx. 40 cm<sup>3</sup>/stroke.



Drum pump

Description	Order number
Drum pump with running gear: For 25 kg drum	169-000-042
For 50 kg drum	169-000-054
Drum pump without running gear: For 25 kg drum	169-000-342

# KFG piston pump unit

## Accessories

### IG502-2-E external control unit

The IG502-2-E is an external control unit with a control display. It controls the turning on and off of the KFG pump by means of interval and pump runtimes. Furthermore, it enables the fill level monitoring of the lubricant reservoir and the evaluation on one piston detector signal. In addition, one can operate the pump unit with it, even from a short distance, e.g. from the cab of a vehicle. It is suitable only for SKF ProFlex systems.



#### External control unit

Description	Order number
External control unit	<b>IG502-2-E</b> (Always please include specification of the control voltage 12 V or 24 V)

### Retaining ring and drilling template

For all KFG units with reservoir capacities up to and including 6 kg, a special drilling template exists as an installation aid made of self-adhesive foil. In addition to that, a stabilizing retaining angle is also available for vertical installation.



#### Retaining ring and drilling template

Description	Order number
Self-adhesive drilling template	<b>951-130-115</b>
Pump retaining plate	<b>881-290-430</b>

### Electrical accessories

The T plug is suitable when additional connectors are required, e.g. for a separate indicator lamp.



#### Electrical accessories

Description	Order number
T-plug M12×1 with two outgoing cables (socket M12×1)	<b>179-990-700</b>

### Pressure gauge

Reed pen pressure gauges with glycerin filling are available for visual documentation of the pressures in the SKF centralized lubrication system. The parts which come into contact with the medium are made of copper alloys. These pressure gauges are suitable for highly dynamic pressure loads and vibrations. The necessary accessory parts for fastening are to be found in the leaflet 1-0103-EN.



#### Pressure gauge

Description	Order number
Pressure gauge, complete:	
0 to 250 bar	<b>169-125-000.U1</b>
0 to 400 bar	<b>169-140-001.U1</b>
Pressure gauge screw union:	
for ø 6 mm tubing	<b>441-106-162</b>
for ø 8 mm tubing	<b>441-108-162</b>
for ø 10 mm tubing	<b>441-110-163</b>
for ø 12 mm tubing	<b>441-112-162</b>



# KFG piston pump unit

## Special designs

### KFG with CAN bus control unit (KFGC)

The KFGC (CAN bus) variant is based on the KFG series and has an integrated CAN bus control unit (LC-CAN5000). The control unit with the CAN bus interface SAE J1939 permits the integration of the lubrication system in the CAN bus and thus enables the input and evaluation of a large number of parameters for the control unit and monitoring of the system. It can however also be used as a stand-alone solution and be connected to a PC via a CAN bus plug/CAN bus adapter or through an infrared interface.

#### Interesting for:

- all those who use CAN bus and who would like to enter, display and evaluate the lubrication system data at a central location
- all those who require individual settings and monitoring of up to four independent valves and/or lubrication circuits (complex systems)
- all those who wish to call up the error log through the PC

#### Result:

Implementation of tailored lubrication concepts for each lubrication circuit in the lubrication system (independent and according to need).

KFGC



KFGC  
(view from below)



#### Note

For inquiries regarding possible variants and designs, please contact an SKF Lubrication Systems representative.

### KFG sea water-resistant

Basically, all KFG variants are available in sea water-resistant versions. Individual components for protection against corrosion (corrosion class C5-M) are coated for this purpose and combined with stainless steel components.



#### Note

For inquiries regarding possible variants and designs, please contact an SKF Lubrication Systems representative.

KFG  
(sea water-resistant design)



# KFG piston pump unit

## Exploded-view and spare parts drawings



**!** Only original spare parts from SKF Lubrication Systems Germany GmbH may be used. Unauthorized alterations to products and the use of non-original spare parts and accessories are not permitted.

**!** Dismantling of the product or individual parts thereof within the statutory warranty period is not permitted and voids any claims.

**!** Repair work may only be performed by the Service department of SKF Lubrication Systems Germany GmbH. In the event of questions in reference to installation or maintenance, please contact SKF Lubrication Systems Germany GmbH or an SKF-authorized dealer or service partner.

**SKF MonoFlex layout A with three pump elements**

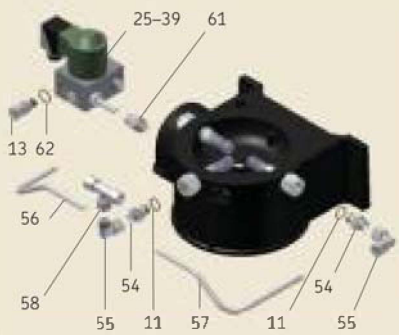

**SKF MonoFlex layout B with two pump elements**

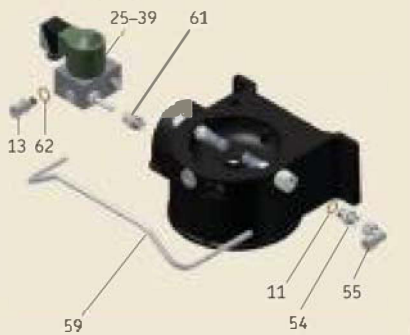

**SKF MonoFlex layout C with two pump elements**

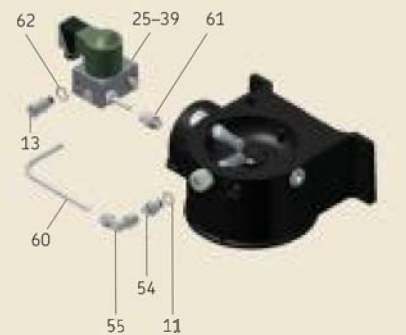

### Wearing parts

Pos.	Order number	ID used in configurator	Description
1	KFG1.U0	E	Pump element with spring-return piston 5,0 cm <sup>3</sup> /min
2	KFG1.U1	A	Pump element with spring-return piston 2,5 cm <sup>3</sup> /min
3	KFG1.U2	B	Pump element with spring-return piston 1,8 cm <sup>3</sup> /min
4	KFG1.U3	C	Pump element with spring-return piston 1,3 cm <sup>3</sup> /min
5	KFG1.U4	D	Pump element with spring-return piston 0,8 cm <sup>3</sup> /min
6	KFG1.U0-E	L	Pump element with positively driven piston 5,0 cm <sup>3</sup> /min
7	KFG1.U1-E	G	Pump element with positively driven piston 2,5 cm <sup>3</sup> /min
8	KFG1.U2-E	H	Pump element with positively driven piston 1,8 cm <sup>3</sup> /min
9	KFG1.U3-E	J	Pump element with positively driven piston 1,3 cm <sup>3</sup> /min

# KFG piston pump unit

## Spare parts

### Spare parts

Pos.	Order number	ID used in configurator	Description
10	301-034	B	Adapter M14x1.5 on G1/4 (sealing ring Item 11 must be ordered separately)
11	DIN7603-A14X18-AL	-	Washer
12	406-413	C	Straight connector for tube ø 6 mm
13	408-413	D	Straight connector for tube ø 8 mm
14	410-403	E	Straight connector for tube ø 10 mm
15	161-210-063	M	PRV <sup>1)</sup> 200 bar, straight connector ø 8 mm
16	161-210-065	N	PRV <sup>1)</sup> 200 bar, straight connector ø 10 mm
17	161-210-062	O	PRV <sup>1)</sup> 200 bar, straight connector ø 12 mm
18	161-210-061	P	PRV <sup>1)</sup> 200 bar, SKF plug connector ø 8 mm
19	161-210-036	G	PRV <sup>1)</sup> 300 bar, female thread G1/4
20	161-210-012	H	PRV <sup>1)</sup> 300 bar, straight connector ø 6 mm
21	161-210-024	J	PRV <sup>1)</sup> 300 bar, straight connector ø 8 mm
22	161-210-066	K	PRV <sup>1)</sup> 300 bar, straight connector ø 10 mm
23	161-210-021	F	PRV <sup>1)</sup> 300 bar, SKF plug connector ø 6 mm
24	161-210-034	L	PRV <sup>1)</sup> 300 bar, SKF plug connector ø 8 mm
25	24-1254-2634	W	Relief valve with PRV <sup>1)</sup> 200 bar, female thread G1/4, 12 V design
26	24-1254-2635	W	Relief valve with PRV <sup>1)</sup> 200 bar, female thread G1/4, 24 V design
27	24-1254-2636	W	Relief valve with PRV <sup>1)</sup> 200 bar, female thread G1/4, 230 V design
28	24-1254-2640	V	Relief valve with PRV <sup>1)</sup> 200 bar, straight connector ø 8 mm, 12 V design
29	24-1254-2641	V	Relief valve with PRV <sup>1)</sup> 200 bar, straight connector ø 8 mm, 24 V design
30	24-1254-2642	V	Relief valve with PRV <sup>1)</sup> 200 bar, straight connector ø 8 mm, 230 V design
31	24-1254-2637	U	Relief valve with PRV <sup>1)</sup> 200 bar, straight connector ø 10 mm, 12 V design
32	24-1254-2638	U	Relief valve with PRV <sup>1)</sup> 200 bar, straight connector ø 10 mm, 24 V design
33	24-1254-2639	U	Relief valve with PRV <sup>1)</sup> 200 bar, straight connector ø 10 mm, 230 V design
34	24-1254-2643	S	Relief valve with PRV <sup>1)</sup> 200 bar, SKF plug connector ø 6 mm, 12 V design
35	24-1254-2644	S	Relief valve with PRV <sup>1)</sup> 200 bar, SKF plug connector ø 6 mm, 24 V design
36	24-1254-2645	S	Relief valve with PRV <sup>1)</sup> 200 bar, SKF plug connector ø 6 mm, 230 V design
37	24-1254-2646	T	Relief valve with PRV <sup>1)</sup> 200 bar, SKF plug connector ø 8 mm, 12 V design
38	24-1254-2647	T	Relief valve with PRV <sup>1)</sup> 200 bar, SKF plug connector ø 8 mm, 24 V design
39	24-1254-2648	T	Relief valve with PRV <sup>1)</sup> 200 bar, SKF plug connector ø 8 mm, 230 V design
40	KFGS1.54	-	Transparent cover for the control unit
41	24-9909-0241	-	KFG filling nipple G1/4 kit
42	24-9909-0248	-	KFG PRV <sup>1)</sup> in the housing 1.5 bar G1/4 kit (rotary application)
43	24-9909-0242	-	KFG screw plug G1/4 kit
44	24-9909-0247	-	KFG PRV in the housing 1.5 bar M20x1.5 kit (rotary application)
45	169-000-174	-	KFG filler socket M20x1.5 kit (Industry, Vehicle)
46	KFG1.128	-	Screw plug, plastic, with O-ring M20x1.5 (Industry, Vehicle)
47	24-9909-0250	-	KFG screw plug, steel M20x1.5 kit (rotary application)
48	24-9909-0244	-	KFG filler coupling G1/4 kit
49	24-9909-0249	-	KFG PRV <sup>1)</sup> on the housing cover 30 bar G1/4 kit (rotary application)
50	24-9909-0243	-	KFG fastening kit (for reservoir capacities from 8 kg to 20 kg only)
51	24-9909-0246	-	KFG sensor/actuator box kit, 230 V (+486) Industry or rotary application
52	24-9909-0254	-	KFG fill level monitoring with square connector kit (rotary application)
53	24-9909-0252	-	KFG fill level monitoring with M12x1 plug (rotary application)
54	408-313	-	Threaded socket
55	443-308-351	-	Elbow connector
56	44-1751-2953	-	Pre-bent tubing
57	44-1751-2954	-	Pre-bent tubing
58	445-808-351	-	Union T
59	44-1751-2956	-	Pre-bent tubing
60	44-1751-2955	-	Pre-bent tubing
61	24-9909-0245	-	SKF MonoFlex return line G1/4 kit
62	DIN7603-A16X20-AL	-	Washer
63	995-800-138	1	2kg reservoir with lid without level monitoring (industry and vehicle application)
63	995-800-508	1	2kg reservoir with lid with mechanically level monitoring (industry and vehicle application)
63	995-800-501	1	2 kg reservoir without lid with capacitive level monitoring (industry and vehicle application)
63	995-800-503	1	Lid for 2 kg reservoir with capacitive level monitoring (industry and vehicle application)
63	995-800-500	3	6kg reservoir without lid and without level monitoring (industry and vehicle application)
63	995-800-504	3	Lid for 6kg reservoir without level monitoring (industry and vehicle application)
63	995-800-509	3	6kg reservoir without lid with mechanically level monitoring (industry and vehicle application)
63	995-800-504	3	Lid for 6kg reservoir with mechanically level monitoring (industry and vehicle application)
63	995-800-500	3	6 kg reservoir without lid and with capacitive level monitoring (industry and vehicle application)
63	995-800-505	3	Lid for 6 kg reservoir with capacitive level monitoring (industry and vehicle application)
63	24-0254-2791	5	10 kg reservoir without or with mechanically level monitoring (industry and vehicle application)
63	24-0254-2790	7	15 kg reservoir without or with mechanically level monitoring (industry and vehicle application)
63	24-0254-2789	8	20 kg reservoir without or with mechanically level monitoring (industry and vehicle application)

<sup>1)</sup> PRV=Pressure relief valve

## The Power of Knowledge Engineering

Combining products, people, and application-specific knowledge, SKF delivers innovative solutions to equipment manufacturers and production facilities in every major industry worldwide. Having expertise in multiple competence areas supports SKF Life Cycle Management, a proven approach to improving equipment reliability, optimizing operational and energy efficiency and reducing total cost of ownership.

These competence areas include bearings and units, seals, lubrication systems, mechatronics, and a wide range of services, from 3-D computer modelling to cloud-based condition monitoring and asset management services.

SKF's global footprint provides SKF customers with uniform quality standards and worldwide product availability. Our local presence provides direct access to the experience, knowledge and ingenuity of SKF people.



CAD models for products shown in this brochure can be downloaded at:  
[skf-lubrication.partcommunity.com](http://skf-lubrication.partcommunity.com)

### Further leaflets:

- 1-0103-EN *Fittings and accessories*
- 1-9201-EN *Feeding lubricants with centralized lubrication systems*
- 1-1701-EN *Pressure switches, product series DSA, DSB, DSC, DSD*
- 1-3010-EN *Modular feeder PSG (Progressive feeder)*
- 1-3015-EN *Sectional feeder VPK (Progressive feeder)*
- 1-3016-EN *Sectional feeder VP (Progressive feeder)*
- 1-3017-EN *Sectional feeder VPB (Progressive feeder)*
- 1-5001-EN *Lubricant distributor SKF MonoFlex (single-line distributor)*



### SKF Lubrication Systems Germany GmbH

Hockenheim Plant  
2. Industriestrasse 4  
68766 Hockenheim  
Germany

Tel. +49 (0)6205 27-0  
Fax +49 (0)6205 27-100

This leaflet was presented to you by:

**MFP**  
AUTOMATION  
ENGINEERING

© SKF, SKF MONOFLEX, SKF PROFLEX and SKF WINDLUB are registered trademarks of the SKF Group.

© SKF Group 2015

The contents of this publication are the copyright of the publisher and may not be reproduced (even extracts) unless prior written permission is granted. Every care has been taken to ensure the accuracy of the information contained in this publication but no liability can be accepted for any loss or damage whether direct, indirect or consequential, arising out of use of the information contained herein.

PUB LS/P2 12649 EN · August 2015 · 1-3030-EN

This publication replaces publications 1-3034-EN and 1-3035-EN.

