



Hose Reels





Why use Hose Reels?

Improve Safety

Hose reels prevent hose from cluttering walkways, reducing slips and falls.

Increase Productivity

Maintaining hose within easy reach saves time and money.

Maximize Equipment Life

Storing hoses and cords on reels prevents them from being stepped on or run over by equipment, increasing their service life.

Minimize Leaks & Spills

Using hose reels reduces leakage and spills of expensive fluids and air.

Why Alemite Reels?

Since 1918, Alemite has been supplying quality hose reels to meet a wide range of applications, from industrial to lube truck to vehicle maintenance facilities. With a reputation for manufacturing the best reels in the industry, Alemite is the brand professionals depend on to deliver high performance and unmatched reliability.

Designed and produced with uncompromising attention to detail, Alemite's full line of reels offers the quality you expect from the leader in lubrication and fluid management equipment. Found everywhere from rugged mines to state-of-the-art fleet garages, Alemite reels are engineered for high performance, durability, and ease of maintenance and operation.



Which Reel is Right for My Needs?



Hose Inside Diameter (ID), Outside Diameter (OD), and Length

Determine size, length, and type of hose/cable needed. Use quality hose rated for the service and operating pressures required. Poor quality hose can expand and contract under pressure surges, causing hose on the reel to bind and rendering it inoperable. For cord reels, use quality cable, properly sized with the correct number of conductors to carry the proper amperage and voltage.

Typical pressure configurations:

High pressure: Handles up to 6,000 psi (414 bar); ideal for dispensing grease.
Medium pressure: Handles up to 1,500 psi (103 bar); ideal for dispensing oil.
Low pressure: Handles up to 300 psi (21 bar); ideal for dispensing air and water.



Size and type of swivel joint and seal for inlet and outlet

In selecting your reel, note the size of your hose versus the inlet and outlet sizes.

Retraction Method

Spring-driven: A drive spring winds as the hose is pulled from the reel, developing the power required to retract the hose when it is no longer needed. This design includes a latch to lock the spring tension during use, maintaining desired hose length. Spring-driven reels require no external power source to drive the reel during retraction.

Hand Crank: Operator must manually crank the reel and guide the hose or cord evenly as it wraps around the drum to reach full capacity. Ideal for applications that require long hose lengths.



Mounting Space and Position

Determine the amount of space available and the mounting position you require: floor, ceiling, wall, bench top, truck, etc.

Ambient Conditions

Will the hose and reel be used indoors, outdoors, in hygienic or corrosive areas? What operating temperatures will the hose and reel be required to withstand?



Additional Options

Consider mounting brackets, hose, swivels, hose stops, etc.

Heavy Duty Reels



There is no substitute for durable, high-quality equipment that will meet the demands of today's tough working conditions. With that in mind, we've designed our heavy-duty reels to meet the reliability needs for virtually any application.

Features and Benefits:

- **Anti-lockout Design:** Ratchet prevents lockup when hose is fully extended, eliminating the need to manually release the pawl at the reel.
- **Superior Performance:** Swivel and reel ball bearings reduce torque load on power spring for smooth retraction and durability.
- **Corrosion Resistant:** Sealed bearings prevent contamination and minimize maintenance.
- **Easy Installation and Maintenance:** Factory lubricated one-piece power spring cassette makes installation safer and maintenance easier.
- **Durable:** Heavy metal arbor design withstands extreme stress and eliminates breakage associated with non-metal and lightweight metal arbors.
- **Adjustable and Versatile:** Five-position guide arm allows hose to release at optimum position. Narrow design allows for maximum use of available space.

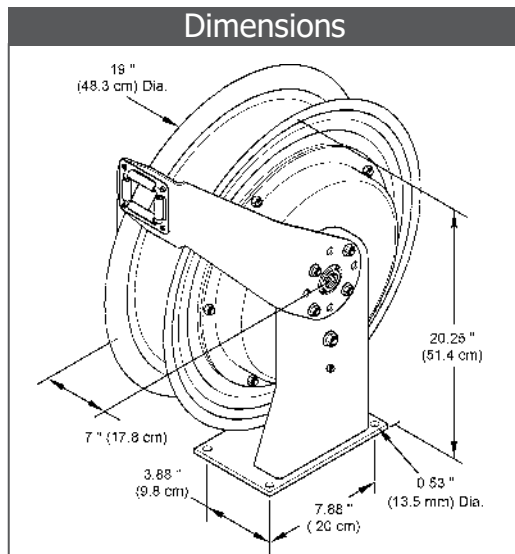

Fluids

Air/Water, Oil, Grease

Mounting

Floor, Wall, Ceiling, Bench Top, Tank

Markets / Applications

Mining, Construction Sites, General Repair Facilities, General Manufacturing, Metals Processing, Pulp/Paper

Reel Package*	Max Pressure	Reel Type	Bare Reel	Delivery Hose Spec.	Weight	Connecting Hose Inlet	Delivery Hose Outlet
8078-E***	200 psi	Air/Water	7336-B	3/8" x 30' (317803-30)	51 lb.	1/2" NPTF(m)	1/4" NPTF(m)
8078-F***	200 psi	Air/Water	7336-B	3/8" x 50' (317803-50)	53 lb.	1/2" NPTF(m)	1/4" NPTF(m)
8078-M***	200 psi	Air/Water	7336-B	1/2" x 50' (317811-50)	61 lb.	1/2" NPTF(m)	1/2" NPTF(m)
8078-C	1,500 psi	Oil	7335-B	1/2" x 30' (317813-30)	56 lb.	1/2" NPTF(m)	1/2" NPTF(m)
8078-D	1,500 psi	Oil	7335-B	1/2" x 50' (317813-50)	58 lb.	1/2" NPTF(m)	1/2" NPTF(m)
8078-A**	6,400 psi	Grease	7334-B	1/4" x 30' (317874-30)	56 lb.	3/8" NPTF(m)	1/4" NPTF(f)
8078-B**	6,400 psi	Grease	7334-B	1/4" x 50' (317874-50)	59 lb.	3/8" NPTF(m)	1/4" NPTF(f)
8078-T	6,400 psi	Grease	7334-B	3/8" x 50' (317870-50)	63 lb.	3/8" NPTF(m)	3/8" NPTF(f)

* Reel Package includes reel, delivery hose, connecting hose, and hose stop

** "Z" swivel must be ordered separately

*** Air coupler for 8078-E & 8078-F is 328030 and air adapter is 328034; air coupler for 8078-M is 328031 and air adapter is 328033

Severe Duty Reels



Tough jobs demand tough equipment. That's why when you're working in extreme conditions you need the strength and durability of Alemite's Severe Duty Reels. Engineered to withstand the most demanding environments, Severe Duty Reels contain all the features of Alemite's Heavy Duty Reels, plus:

Features and Benefits:

- **Easy Installation and Maintenance:** Factory lubricated one-piece power spring cassette makes installation safer. Removable rollers provide easy cleaning and service.
- **Durable:** Heavy metal arbor design withstands extreme stress and eliminates breakage associated with non-metal and lightweight metal arbors. The 1/4 in (6 mm) base is thicker than our Heavy Duty reel and is fully welded to ensure off-road stability.
- **Corrosion Resistant:** Weather-resistant gaskets and O-rings protect internal components from corrosion.

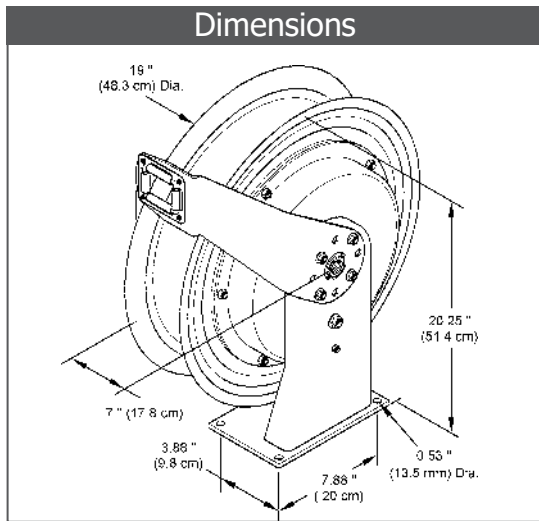

Fluids

Air/Water, Oil, Grease, Diesel Fuel, Gasoline

Mounting

Floor, Wall, Ceiling, Bench Top, Tank

Markets / Applications

Lube Trucks, Mining, Construction Sites, General Industrial Manufacturing, Metals Processing, Pulp/Paper, Marine

Reel Package*	Max. Pressure	Reel Type	Bare Reel	Delivery Hose Spec.	Connecting Hose	Weight	Connecting Hose Inlet	Delivery Hose Outlet
8078-R**	200 psi	Air/Water	7336-C	3/8" x 30' (317803-30)	317811-2	53 lb.	1/2" NPTF(m)	1/4" NPTF(m)
8078-J**	200 psi	Air/Water	7336-C	3/8" x 50' (317803-50)	317811-2	53 lb.	1/2" NPTF(m)	1/4" NPTF(m)
8078-K	300 psi	Fuel	7337-C	3/4" x 30' (317868-30)	317868-2	71 lb.	3/4" NPTF(m)	3/4" NPTF(m)
8078-S	3000 psi	Twin Hose	7339	3/8" x 30' (340326-30)	317882-2	67 lb.	3/8" NPSM(f)	3/8" NPTF(m)
8078-P	1,500 psi	Oil	7335-C	1/2" x 30' (317813-30)	317813-2	58 lb.	1/2" NPTF(m)	1/2" NPTF(m)
8078-H	1,500 psi	Oil	7335-C	1/2" x 50' (317813-50)	317813-2	60 lb.	1/2" NPTF(m)	1/2" NPTF(m)
8078-N	6,000 psi	Grease	7334-C	1/4" x 30' (317874-30)	317876-2	58 lb.	3/8" NPTF(m)	1/4" NPTF(f)
8078-G	6,000 psi	Grease	7334-C	1/4" x 50' (317874-50)	317876-2	61 lb.	3/8" NPTF(m)	1/4" NPTF(f)

* Reel Package includes reel, delivery hose, connecting hose, and hose stop

** Air Coupler (328030) & Air Adapter (328034)

Narrow Double Post

Reels



Alemite's dual arm hose reels are engineered for optimal durability and reliability, ensuring they will withstand the toughest outdoor applications. The dual arm design provides additional strength and stability in harsh off-road environments. The base features a narrow, space-saving footprint and slots to ensure easy mounting.

Features and Benefits:

- **Narrow Design:** 8.5" wide with slot mounting holes for easy installation.
- **Superior Performance:** Removable rollers provide easy cleaning and service. The ratchet pawl cartridge allows for fast serviceability.
- **Stress Resistant:** Heavy metal arbor design withstands extreme stress.
- **Easy Installation and Maintenance:** Factory lubricated one-piece power spring cassette makes installation safer and maintenance easier.
- **Durable:** Ratchet prevents lockup when hose is fully extended, eliminating the need to manually release the pawl at the reel.
- **Adjustable and Versatile:** Five-position guide arm provides versatile floor, wall and ceiling mounting and allows hose to release at optimum position.

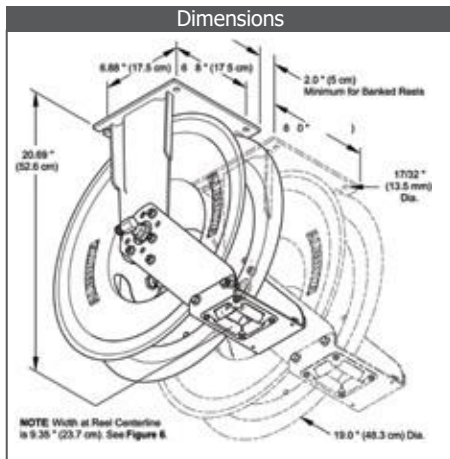

Fluids

Air/Water, Oil, Grease, Diesel Fuel, Hydraulic Fluid

Mounting

Wall, Ceiling, Floor, Bench Top, Tank

Markets /Applications

Municipalities, Service Trucks, Mining, Golf Courses, Automotive Service Centers, Fleet & Aircraft Maintenance Facilities

Product #	Description	Bare Reel	Delivery Hose Spec.	Reel Inlet	Delivery Hose Outlet	Hose Stop	Max. Pressure
8081-A	1/4" x 30' High Pressure Assembly	7370	317874-30	3/8" NPSM(m)	1/4" NPTF(f)	337437	6,500 psi
8081-B	1/4" x 50' High Pressure Assembly	7370	317874-50	3/8" NPSM(m)	1/4" NPTF(f)	337437	6,500 psi
8081-C	1/2" x 40' Medium Pressure Assembly	7371	317813-40	1/2" NPSM(m)	1/2" NPTF(m)	337437	1,800 psi
8081-D	1/2" x 50' Medium Pressure Assembly	7371	317813-50	1/2" NPSM(m)	1/2" NPTF(m)	337437	1,800 psi
8081-E	3/8" x 40' Low Pressure Assembly	7372	317803-40	1/2" NPSM(m)	1/4" NPFT(m)	337437	200 psi
8081-F	3/8" x 50' Low Pressure Assembly	7372	317803-50	1/2" NPSM(m)	1/4" NPTF(m)	337437	200 psi
8081-G	1/2" x 50' Low Pressure Assembly	7371	317811-50	1/2" NPSM(m)	1/2" NPTF(m)	337437	200 psi
8081-H	3/8" x 30' High Pressure Assembly (Twin Hose)	7374	340326-30	3/8" NPSM(m) (both inlets)	3/8" NPTF(m)	339389-3	3,000 psi
8081-J	3/8" x 50' High Pressure Assembly	7370	317870-50	3/8" NPTF(m)	1/4" NPTF(f)	337437	4,000 psi
8081-K	3/4" x 30' Low Pressure Fuel Reel Assembly	7373	317868-30	3/4" NPSM(m)	3/4" NPTF(m)	339389	200 psi

Shielded Reels

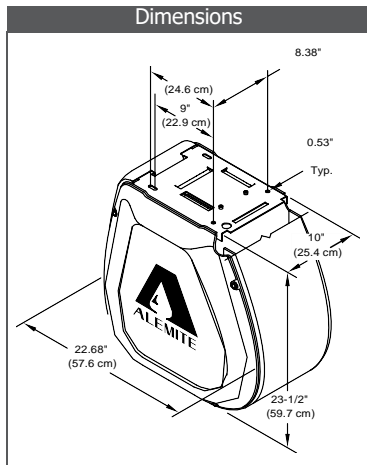

When your workplace is in view of your customers, cleanliness and appearance are important. For such situations, our shielded reels offer the perfect blend of looks and performance. Placed together in a bank, shielded reels feature a track system for easy installation. Reels may also be customized with your logo.

Features and Benefits:

- **Durable, Attractive Design:** Side panels are constructed of ABS Polymer for impact and stain resistance. Attractive casing offers enhanced eye appeal.
- **Quick Installation:** Track system makes installation of reels quick and easy. Banked shields butt against one another to minimize space used.
- **Easy Maintenance:** Roller guides are attached to the hose reel for convenient servicing.



Fluids

Air/Water, Oil, Grease, ATF, Hydraulic Oil

Mounting

Ceiling

Markets /Applications

Automotive Dealerships, Quick Lubes, Automotive Repair Garages, Machine Shops, Transit Facilities, Large Fleet Shops

Product #	Reel Type	Pressure	Bare Reel	Delivery Hose Spec.	Connecting Hose	Weight	Connecting Hose Inlet	Delivery Hose Outlet
8079-A*	Grease	6,000 psi	7334-D	1/4" x 30' (317874-30)	317876-2	73 lb.	3/8"(m)	1/4"(f)
8079-B*	Grease	6,000 psi	7334-D	1/4" x 50' (317874-50)	317876-2	76 lb.	3/8"(m)	1/4"(f)
8079-C	Oil	1,500 psi	7335-D	1/2" x 30' (317813-30)	317813-2	73 lb.	1/2"(m)	1/2"(m)
8079-D	Oil	1,500 psi	7335-D	1/2" x 50' (317813-50)	317813-2	75 lb.	1/2"(m)	1/2"(m)
8079-E	Air/Water	300 psi	7336-D	3/8" x 30' (317803-30)	317811-2	68 lb.	1/2"(m)	1/4"(m)
8079-F	Air/Water	300 psi	7336-D	3/8" x 50' (317803-50)	317811-2	70 lb.	1/2"(m)	1/4"(m)

* Reel Package includes reel, delivery hose, connecting hose, and hose stop

Shielded Reel Accessories



Cabinet Kit
7331



End Panel Kit
339371

Product #	Description	Weight
7331*	Cabinet kit for one cabinet hose reel	10.5 lb.
339371**	End panels for one bank of cabinet hose reels	5.4 lb.
339368	Strut for single reel installation	N/A

* Order one per reel.

** Order one kit for each bank of reels.

Twin Hose Reels



Alemite's twin hose reels are constructed to the same high quality standards as all of our reels. These reels are available in severe duty, narrow double post, and high-capacity double post designs.

Features and Benefits:

- **Long-life Design:** Sealed spring cassette protects the power spring from corrosion caused by water and dirt. Sealed rollers eliminate contamination that can bind the hose guide rollers. Lifetime Warranty on Hose Guide Assembly.
- **Superior Bearing Performance:** Reduces torque load on power spring for smooth retraction and durability.
- **Easy Installation:** Outlet port swivel nut makes installing the delivery hose quick and easy.
- **Versatile Mounting:** Adjustable arm allows for mounting on a floor, ceiling or wall. Narrow width allows for more reels to be mounted along a truck bed.
- **Strength and Stability:** Double arm provides extra support for a larger hose during use. Four-corner bolt hole pattern on outside of base provides extra stability.
- **High Volume Capacity Flow Passage:** Reduces ill rate time and improves efficiency.



Fluids

Air/Water, Oil, Grease, Diesel Fuel, Gasoline

Mounting

Service Trucks, Walls, Tanks, Construction Equipment, Ceiling

Markets /Applications

Trucks, Garages, Cranes, Construction Equipment, Hydraulic Tools, Vehicle Extraction Tools, Aerial Device, Hydraulic Cylinders, Tree Cutters, Digger Derricks, Railroad Maintenance Tools

Product #	Pressure	Reel Type	Bare Reel	Delivery Hose Spec.	Weight	Reel Inlet	Delivery Hose Outlet	Connecting Hose*	Connecting Hose Inlet*
8078-S	3,000 psi	Twin Hose	7339	3/8" x 30' (340326-30)	67 lb.	3/8" NPSM(f)	3/8" NPTF(m)	317882-2	3/8" NPSM(f)
8080-K	3,000 psi	Twin Hose	7343	3/8" x 80' (340326-80)	165 lb.	3/8" NPSM(f)	3/8" NPSM(m)	317882-2	3/8" NPSM(f)
8080-L	3,000 psi	Twin Hose	7344	1/2" x 80' (340328-80)	180 lb.	1/2" NPSM(f)	1/2" NPTF(m)	No part no.	1/2" NPSM(f)
8081-H	3,000 psi	Twin Hose	7374	3/8" x 30' (340326-30)	70 lb.	3/8" NPSM(f)	3/8" NPTF(m)	317882-2	3/8" NPSM(m)

* Hoses are not supplied with the assembly

High Capacity Reels



If you need high-volume delivery in a reel that will withstand the most severe outdoor conditions, then you need Alemite's High Capacity Reel. Capable of handling up to 100 ft (30 m) of 1/2 in (13 mm) diameter or up to 50 ft (15 m) of 1 in (25 mm) diameter hose, these corrosion-resistant reels are ideal for severe conditions.

Features and Benefits:

- **Long-life Design:** Sealed spring cassette protects the power spring from corrosion caused by water and dirt. Sealed rollers eliminate contamination that can bind the hose guide rollers. Lifetime Warranty on Hose Guide Assembly.
- **Superior Bearing Performance:** Reduces torque load on power spring for smooth retraction and durability.
- **Easy Installation:** Outlet port swivel nut makes installing the delivery hose quick and easy.
- **Versatile Mounting:** Adjustable arm allows for mounting on a floor, ceiling or wall. Narrow width allows for more reels to be mounted along a truck bed.
- **Strength and Stability:** Double arm provides extra support for a larger hose during use. Four-corner bolt hole pattern on outside of base provides extra stability.
- **High Volume Capacity Flow Passage:** Reduces fill rate time and improves efficiency.

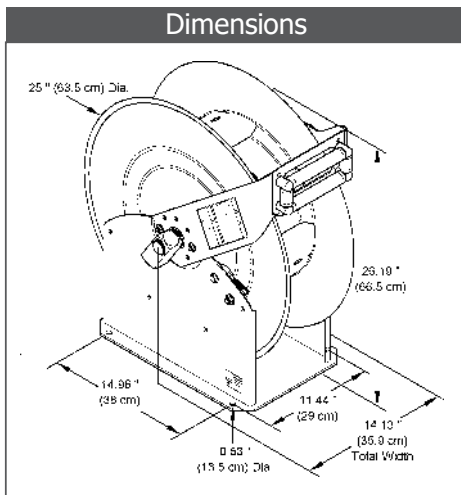

Fluids

Air/Water, Oil, Grease, Diesel Fuel, Gasoline

Mounting

Floor, Wall, Ceiling, Truck Bed

Markets /Applications

Lube Trucks, Maintenance Facilities, Industrial and High Flow Applications, Marine

Product #	Max. Pressure	Reel Type	Bare Reel	Delivery Hose Spec.	Weight	Reel Inlet	Delivery Hose Outlet
8080-C	300 psi	Air/Water	7341	1/2" x 80' (317811-80)	115 lb.	1/2" NPTF(f)	1/2" NPTF(m)
8080-D	300 psi	Air/Water	7341	1/2" x 100' (317811-100)	125 lb.	1/2" NPTF(f)	1/2" NPTF(m)
8080-B	1,500 psi	Oil	7341	1/2" x 80' (317813-80)	125 lb.	1/2" NPTF(f)	1/2" NPTF(m)
8080-H	1,500 psi	Oil	7341	1/2" x 100' (317813-100)	154 lb.	1/2" NPTF(f)	1/2" NPTF(m)
8080-A*	6,000 psi	Grease	7340	3/8" x 80' (317870-80)	120 lb.	3/8" NPTF(m)	1/4" NPTF(f)
8080-E	1,000 psi	Fuel	7342	3/4" x 50' (317868-50)	145 lb.	1" NPTF(f)	3/4" NPTF(f)
8080-F	1,000 psi	Fuel	7342	3/4" x 70' (317868-70)	155 lb.	1" NPTF(f)	3/4" NPTF(f)
8080-G	1,000 psi	Fuel	7342	1" x 50' (317869-50)	165 lb.	1" NPTF(f)	1" NPTF(f)
8080-J	150 psi	Fuel	7342	1" x 50' (339634-50)	165 lb.	1" NPTF(f)	1" NPTF(f)
8080-K	3,000 psi	Twin Hose	7343	3/8" x 80' (340326-80)	165 lb.	3/8" NPSM(f)	3/8" NPSM(m)
8080-L	3,000 psi	Twin Hose	7344	1/2" x 80' (340328-80)	180 lb.	1/2" NPSM(f)	1/2" NPTF(m)

Hand Crank

Reels



Alemite's Hand Crank Reels are designed for heavy duty applications that require long hose lengths. Ideal for industrial or outdoor use, these reels are engineered to provide trouble-free performance and long product life.

Features and Benefits

- **Quality Design:** Full low shaft and ball bearing swivel. Swivel is zinc-plated with Viton® O-Ring seals.
- **Rugged Construction:** Steel drum and all bolted construction. Vibration-proof self-locking fasteners.
- **Versatile:** Reel can be easily converted to power-driven type with motor mounting at either end of reel.
- **Safe:** Adjustable spool rotation drag eliminates hose backlash when de-reeling. Lock pin prevents spool rotation when reel is not in use.
- **Low Maintenance:** Dual main bearings never need lubrication.

Dimensions

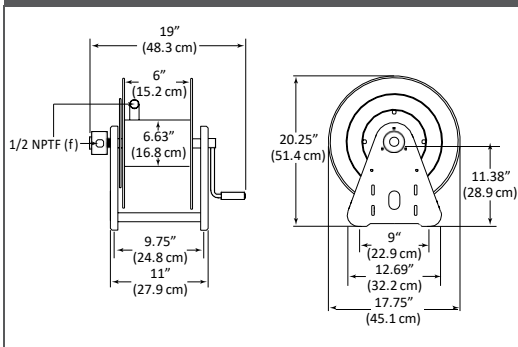

Fluids

Air/Water, Oil, Soaps, Chemicals

Mounting

Floor, Wall, Bench Top, Truck

Markets /Applications

Lawn Care, Laboratories, Dairies, Pest Control, Grounds Maintenance, Agriculture, Industrial Plants, Roofing Contractors, Automotive Service Centers, Nurseries, Greenhouses, Golf Courses, Orchards, Hotels & Resorts, Car Washes, Tire Service Trucks, Restaurants, Athletic Fields, Marine Applications

Product #	Max. Pressure	Max. Hose Capacity	Weight	Reel Inlet	Reel Outlet
7350	1,000 psi	1/2" x 100'	12 lb.	1/2" NPTF(f)	1/2" NPTF(f)

Oxygen/Acetylene Reels



When you're working with volatile elements, you need equipment you can rely on. That's why we engineered our Oxygen/Acetylene Reels with safety and ease of maintenance in mind. Improve your welding or cutting operation with these reels by eliminating the hazards of loose hose.

Features and Benefits:

- **Anti-lockout Feature:** Ratchet prevents lockup when hose is fully extended, eliminating the need to manually release the pawl at the reel.
- **Superior Bearing Performance:** Heavy duty swivel and reel ball bearings reduce torque load on power spring for smooth retraction and durability.
- **Long-life Design:** Bearings are sealed to prevent contamination and minimize maintenance. Durable metal arbor design withstands extreme stress and eliminates breakage associated with non-metal and lightweight metal arbors.
- **Versatile:** Five-position guide arm enables hose to release at optimum position.
- **Easy Installation and Maintenance:** Factory-lubricated one-piece power spring cassette makes installation safer and maintenance easier.
- **UL Listed.**

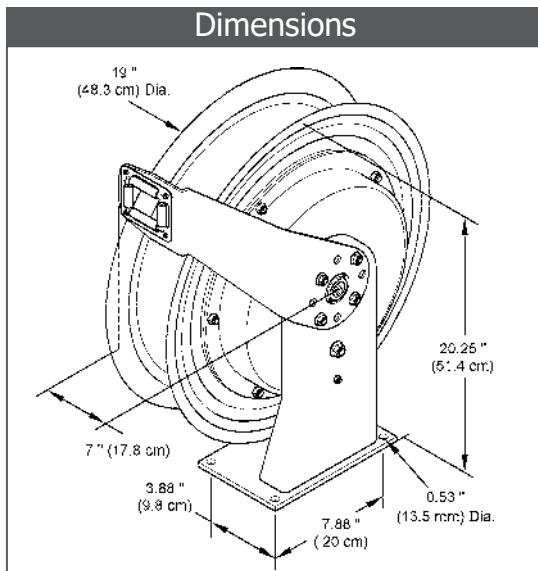

Fluids

Oxygen/Acetylene

Mounting

Floor, Wall, Ceiling, Truck Bed, Workbench

Markets / Applications

Manufacturing Facilities, Machine Shops, Automotive Repair Garages, Mines, Railroad Industry, Construction Sites, Pipelines

Reel Package*	Description	Bare Reel	Delivery Hose Spec.	Weight	Oxy & Ace Inlets	Delivery Hose Connections
8071-A	200 psi Heavy-Duty Oxy/Ace Reel	7338-B	1/4" x 30' (339539-30)	54 lb.	1/4" NPTF(f)	9/16-18"(f) Threads
8071-B	200 psi Heavy-Duty Oxy/Ace Reel	7338-B	1/4" x 50' (339539-50)	56 lb.	1/4" NPTF(f)	9/16-18"(f) Threads
8071-D	200 psi Severe-Duty Oxy/Ace Reel	7338-C	1/4" x 50' (339539-50)	57 lb.	1/4" NPTF(f)	9/16-18"(f) Threads

* Reel Package includes reel, delivery hose, and hose stop

Stainless Steel

Reels



The stainless steel design means this reel is durable and corrosion-resistant, making it an ideal choice for outdoor applications or where hygiene and quick cleanup are important. Alemite's Stainless Steel reel will provide years of trouble-free operation and easy maintenance.

Features and Benefits

- **Convenient Locking Hose:** Ratchet locks hose into position.
- **Long-life Design:** Spring and ratchet are protected by drum. All vital parts are housed inside a watertight casing.
- **Easy Cleaning and Servicing:** Minimum number of joints and smooth, sloping surfaces simplify maintenance.
- **Safe Operation:** Double bearings and "cross-curved" spring material for safe, reliable operation.

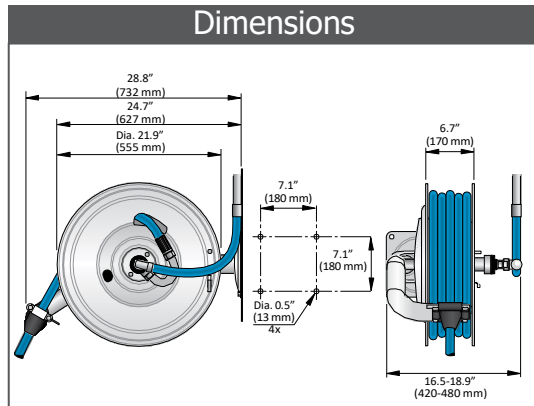

Fluids

Air/Water, Oil, Soaps, Chemicals

Mounting

Floor, Wall, Ceiling, Bench

Markets / Applications

Food Grade Wash Down Environments, Food Processing Areas, Outdoors, High Corrosive Areas, Bakeries, Breweries, Pulp and Paper Processing, Metals Processing, General Manufacturing, Mines

Product #	Max. Pressure	Max. Hose Capacity	Weight	Reel Inlet**	Reel Outlet**
7250-A*	1,450 psi	1/2" x 82'	36 lb.	1/2" NPTF(m)	1/2" NPTF(m)
7250-B*	2,600 psi	3/8" x 82'	36 lb.	3/8" NPTF(m)	3/8" NPTF(m)

* Includes hose stop

**With 30° internal seat for NPSM female swivel connection

Corrosion-Resistant Aluminum

Reels



Alemite's Corrosion-Resistant Aluminum Reels are constructed with die-cast aluminum for superior strength and durability. Their heavy duty design and compatibility with long, heavy hoses make them a great choice for the toughest applications.

Features and Benefits

- **Superior Performance:** Drum and swivel feature ball bearings, which reduce friction and wear.
- **Corrosion Resistant:** Structural components are powder-coated aluminum. Spring and bearing are protected by an ABS plastic case.
- **Adjustable:** Outlet arm and mounting bracket are adjustable to provide optimal pull-out angle for hose, minimizing friction.
- **Convenient Locking Hose:** Ratchet locks hose at desired length; hose is easily released by gentle pulling motion.

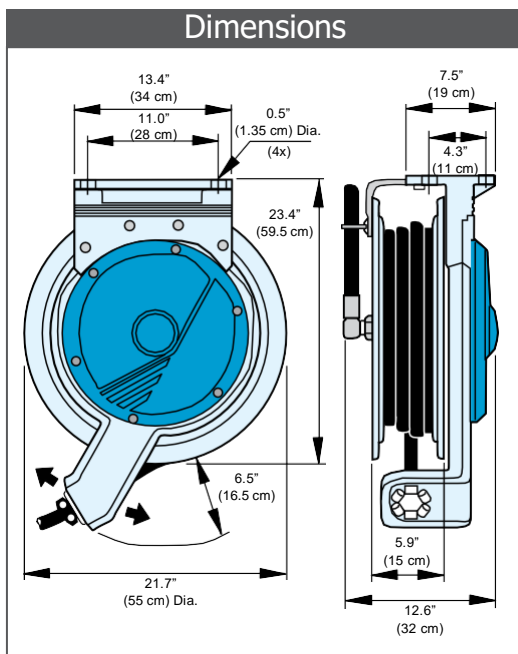

Fluids

Air/Water, Oil, Grease, Diesel

Mounting

Floor, Wall, Ceiling, Bench

Markets / Applications

Pulp & Paper, Fueling, Industrial and Outdoor Applications, Marine, General Manufacturing

Product #	Inlet/Outlet*	Max. Hose Length	Max. Pressure	Application	Weight
7254-A	1/2" NPTF(m)	98' (1/2" Dia.)	725 psi	Air/Water/Oil	32 lb.
7254-B	3/4" NPTF(m)	50' (15m) (3/4" Dia.)	725 psi	Diesel/Oil	32 lb.

* Includes hose stop

** With 30° internal seat for NPSM female swivel connection

Standard and Heavy Duty Electric Cord

Reels

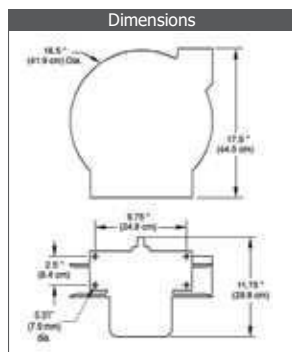

Alemite Heavy Duty Electric Cord Reels ensure your cords are within an arm's reach, but out of the way. By minimizing the hazards of dangling electrical cords, these reels improve safety, convenience and productivity.

Features and Benefits

- **Long-life Design:** Adjustable roller guide arm with nylon guide rollers to reduce drag and wear.
- **Easy to Use:** Adjustable bumper stop allows any desired length of cord to be maintained outside the reel. Automatic spring retraction for quick cord rewind.
- **Quality Construction:** Reel drive springs manufactured from high-quality, scaleless blue tempered steel. Steel construction provides optimal reliability in industrial applications.
- **UL Listed and CSA Certified.**

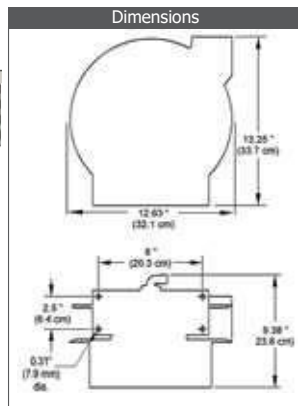

Features and Benefits

- **Easy to Use:** Spring retractable, tangle-free encased cord makes winding and storage safe and easy.
- **Durable:** High-quality, impact-resistant polypropylene case features abrasion and corrosion resistant baked-on powder coat inish.
- **Versatile:** Adjustable cord stop with dual roller non-snag cord guide and 60" lead-in cord with convenient 180 degree swivel.
- **Safe:** GFCI receptacle protects from line-to-ground shocks hazards caused by faulty tools or appliances connected to reel.
- **UL Listed and CSA Certified.**



CAUTION:

The GFCI receptacle is designed to protect people from the line-to-ground shock hazards which could occur from defective power tools or appliances operating from this device or from down line outlets protected by it.

The Ground Fault Circuit Interrupter does not protect against short circuits or overloads. This is the function of the fuse or circuit breaker.

Persons with heart problems or other conditions that make them susceptible to electric shock may still be injured by ground faults on circuits protected by the GFCI receptacle. No safety device will protect against all hazards or carelessly handled electrical equipment.



Mounting

Floor, Wall, Ceiling, Bench Top, Truck

Markets / Applications

Industrial Plants, Automotive Service Centers & Garages, Tire Stores, Service Trucks, Agriculture, Fleet Maintenance Facilities, Aircraft Maintenance, Woodworking, Workshops, Electric Tools

Product #	Outlet	Cord Size	Number of Conductors	Cord Length	Volts	Ampere	Weight
7260	Duplex with GFCI	12 gauge (3.32 mm)	3	45' (14 m)	115V	20 amp	30 lb. (14 kg)
7261	RV Plug	10 gauge (5.37 mm)	3	50' (15 m)	115V	35 amp	47 lb. (22 kg)

Economy Electric Cord

Reels

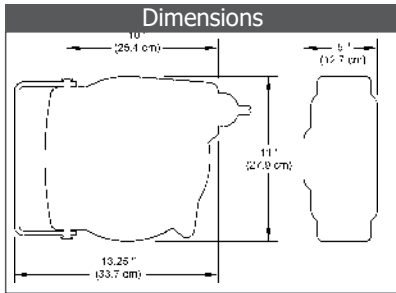

CAUTION:

Risk of fire! Not for use above hazardous locations or near flammable vapors.

Alemite Standard Duty Electric Cord Reels ensure your cords are within an arm's reach, but out of the way. By minimizing the hazards of dangling electrical cords, these reels improve safety, convenience and productivity.

Features and Benefits

- **Safe:** Tangle-free encased cord for easy winding and safe storage.
- **Durable:** High-quality, impact-resistant polypropylene case.
- **Adjustable:** Cord is spring retractable with latch and features an adjustable cord stop with dual roller and non-sag cord guide with 60" lead-in cord.
- **Versatile:** Convenient 180-degree swivel for easy handling. Standard Duty Light reel is handled with grounded outlet, and a magnetic hanger.
- **UL and CUL Listed.**



Mounting

Floor, Wall, Ceiling

Markets / Applications

Industrial Plants, Automotive Service Centers & Garages, Tire Stores, Service Trucks, Agriculture, Fleet Maintenance Facilities, Aircraft Maintenance, Woodworking, Workshops, Electric Tools

Product #	Cord Size	Conductors	Cord Length	Volts	Ampere	Weight	Other Info.
7262-A	12 gauge	3	40'	125V	15 amp	15.4 lb.	Triple outlets
7262-B	16 gauge	3	50'	125V	10 amp	13 lb. (5.8 kg)	Fluorescent

Compact Air/Water

Reels



This spring-driven, self-retracting air/water reel features a rugged housing and pivoting mounting bracket. This lightweight reel is ideal for dispensing washer fluids or antifreeze.

Features and Benefits

- **Safe:** Spring-driven retractable hose
- **Durable:** Lightweight and rugged molded housing
- **Adjustable:** Pivoting mounting bracket for ease of use
- **Versatile:** 52' of 5/16" diameter polyurethane delivery hose



Mounting

Floor, Wall, Ceiling

Markets / Applications

Manufacturing Plants, Vehicle Service Facilities, Rental Car Services, Car Washes, Assembly Lines, Marine Maintenance, Quick Lubes, Air Powered Tools

Product #	Inside Diameter	Length	Thread Size Inlet / Outlet	Reel Port Inlet Swivel/Outlet	Max. Pressure	Temp. Range
8051-1	5/16"	52'	1/4" NPT(f) / 1/4" NPT(m)	3/8" NPT(f) / 1/4" NPT(m)	218 psi	23° to 104° F

Hose Reel Accessories

Hose Stops



Product #	Hose ID
337437	.318" to .846"
339538	.530" (twin line)
339389	1.060" to 1.30"
339389-1	1.390" to 1.550"
339389-2 (fuel hose)	1.060" to 1.380"
339389-3	.680" (twin line)
339389-4	.810" (twin line)

Swivels

High Pressure Swivels - Grease



Thread (m) x (m)	Straight	90°	Z-Type	Pressure Rating
1/4" NPTF x 1/2"-27	B52750	B52751	B52752	10,000 psi (690 bar)
1/8" NPTF x 1/8" NPTF	54730	N/A	54732	10,000 psi (690 bar)
1/4" NPTF x 1/4" NPTF	B321320	N/A	B331107	10,000 psi (690 bar)

High Pressure Swivels - Oil



Thread (m) x (m)	Straight	Pressure Rating
1/2" NPTF x 1/2" NPTF	332912	7,000 psi (483 bar)

Hoses

Fuel Hoses

Product #	Length	Coupling Spec.	Hose ID	Working psi	Burst psi
317868-2	2'	3/4" NPTF(m) x 3/4" NPTF(m)	3/4"	1,250 psi	5,000 psi
317868-30	30'	3/4" NPTF(m) x 3/4" NPTF(m)	3/4"	1,250 psi	5,000 psi
317868-50	50'	3/4" NPTF(m) x 3/4" NPTF(m)	3/4"	1,250 psi	5,000 psi
317868-70	70'	3/4" NPTF(m) x 3/4" NPTF(m)	3/4"	1,250 psi	5,000 psi
317869-50	50'	1" NPTF(m) x 1" NPTF(m)	1"	1,000 psi	4,000 psi

Welding Hoses

Product #	Length	Coupling Spec.	Hose ID	Working psi
339539-30	30'	9/16"-18(f)	1/4" Twin	200 psi
339539-50	50'	9/16"-18(f)	1/4" Twin	200 psi

High Pressure Grease Hoses



Product #	Length	Coupling Thread	Hose ID	Working psi*	Burst psi
317853-5	5' (1.5 m)	1/8" NPTF(m) x 3/8" NPTF(m)	1/4" (6 mm)	4,400 psi (303 bar)	11,000 psi
317870-50	50' (15 m)	3/8" NPTF(m) x 1/4" NPTF(f)	3/8" (8 mm)	6,400 psi (441 bar)	16,000 psi
317870-70	70' (21 m)	3/8" NPTF(m) x 1/4" NPTF(f)	3/8" (8 mm)	6,400 psi (441 bar)	16,000 psi
317870-80	80' (24 m)	3/8" NPTF(m) x 1/4" NPTF(f)	3/8" (8 mm)	6,400 psi (441 bar)	16,000 psi
317874-30	30' (9 m)	3/8" NPTF(m) x 1/4" NPTF(f)	1/4" (6 mm)	8,000 psi (552 bar)	20,000 psi
317874-50	50' (15 m)	3/8" NPTF(m) x 1/4" NPTF(f)	1/4" (6 mm)	8,000 psi (552 bar)	20,000 psi
317875-1F	1.5' (0.5 m)	1/2"-27 NS Taper(f) x 1/2"-27 NS Taper(f)	1/4" (6 mm)	8,000 psi (552 bar)	20,000 psi
317875-7	7' (2 m)	1/2"-27 NS Taper(f) x 1/2"-27 NS Taper(f)	1/4" (6 mm)	8,000 psi (552 bar)	20,000 psi
317875-10	10' (3 m)	1/2"-27 NS Taper(f) x 1/2"-27 NS Taper(f)	1/4" (6 mm)	8,000 psi (552 bar)	20,000 psi
317875-14	14' (4 m)	1/2"-27 NS Taper(f) x 1/2"-27 NS Taper(f)	1/4" (6 mm)	8,000 psi (552 bar)	20,000 psi
317875-20	20' (6 m)	1/2"-27 NS Taper(f) x 1/2"-27 NS Taper(f)	1/4" (6 mm)	8,000 psi (552 bar)	20,000 psi
317875-25	25' (8 m)	1/2"-27 NS Taper(f) x 1/2"-27 NS Taper(f)	1/4" (6 mm)	8,000 psi (552 bar)	20,000 psi
317875-30	30' (9 m)	1/2"-27 NS Taper(f) x 1/2"-27 NS Taper(f)	1/4" (6 mm)	8,000 psi (552 bar)	20,000 psi
317875-40	40' (12 m)	1/2"-27 NS Taper(f) x 1/2"-27 NS Taper(f)	1/4" (6 mm)	8,000 psi (552 bar)	20,000 psi
317875-50	50' (15 m)	1/2"-27 NS Taper(f) x 1/2"-27 NS Taper(f)	1/4" (6 mm)	8,000 psi (552 bar)	20,000 psi
317875-70	70' (21 m)	1/2"-27 NS Taper(f) x 1/2"-27 NS Taper(f)	1/4" (6 mm)	8,000 psi (552 bar)	20,000 psi
317876-2	2' (0.6 m)	3/8" NPTF(m) x 3/8" NPTF(m)	1/4" (6 mm)	8,000 psi (552 bar)	20,000 psi
317876-5	5' (1.5 m)	3/8" NPTF(m) x 3/8" NPTF(m)	1/4" (6 mm)	8,000 psi (552 bar)	20,000 psi
317878-10	10' (3 m)	1/2"-27 NS Taper(f) x 1/2"-27 NS Taper(f)	3/8" (8 mm)	6,400 psi (441 bar)	16,000 psi
317878-50	50' (15 m)	1/2"-27 NS Taper(f) x 1/2"-27 NS Taper(f)	3/8" (8 mm)	6,400 psi (441 bar)	16,000 psi
317878-70	70' (21 m)	1/2"-27 NS Taper(f) x 1/2"-27 NS Taper(f)	3/8" (8 mm)	6,400 psi (441 bar)	16,000 psi
317882-2	2' (0.6 m)	3/8" NPTF(m) x 3/8" NPTF(m)	3/8" (8 mm)	6,400 psi (441 bar)	16,000 psi
317882-7	7' (2 m)	3/8" NPTF(m) x 3/8" NPTF(m)	3/8" (8 mm)	6,400 psi (441 bar)	16,000 psi

* Maximum working pressure with grease only.

Medium Pressure Oil Hoses



Product #	Length	Coupling Spec.	Hose ID	Working psi	Burst psi
317813-1	1'	1/2" NPTF(m) x 1/2" NPTF(m)	1/2"	2,000 psi	8,000 psi
317813-2	2'	1/2" NPTF(m) x 1/2" NPTF(m)	1/2"	2,000 psi	8,000 psi
317813-5	5'	1/2" NPTF(m) x 1/2" NPTF(m)	1/2"	2,000 psi	8,000 psi
317813-5F	5-1/2'	1/2" NPTF(m) x 1/2" NPTF(m)	1/2"	2,000 psi	8,000 psi
317813-7	7'	1/2" NPTF(m) x 1/2" NPTF(m)	1/2"	2,000 psi	8,000 psi
317813-12	12'	1/2" NPTF(m) x 1/2" NPTF(m)	1/2"	2,000 psi	8,000 psi
317813-15	15'	1/2" NPTF(m) x 1/2" NPTF(m)	1/2"	2,000 psi	8,000 psi
317813-20	20'	1/2" NPTF(m) x 1/2" NPTF(m)	1/2"	2,000 psi	8,000 psi
317813-25	25'	1/2" NPTF(m) x 1/2" NPTF(m)	1/2"	2,000 psi	8,000 psi
317813-30	30'	1/2" NPTF(m) x 1/2" NPTF(m)	1/2"	2,000 psi	8,000 psi
317813-40	40'	1/2" NPTF(m) x 1/2" NPTF(m)	1/2"	2,000 psi	8,000 psi
317813-50	50'	1/2" NPTF(m) x 1/2" NPTF(m)	1/2"	2,000 psi	8,000 psi
317813-70	70'	1/2" NPTF(m) x 1/2" NPTF(m)	1/2"	2,000 psi	8,000 psi
317813-80	80'	1/2" NPTF(m) x 1/2" NPTF(m)	1/2"	2,000 psi	8,000 psi
317813-100	100'	1/2" NPTF(m) x 1/2" NPTF(m)	1/2"	2,000 psi	8,000 psi
317828-3	3'	3/8" NPTF(m) x 1/2" NPTF(m)	1/2"	2,000 psi	8,000 psi
317828-5	5'	3/8" NPTF(m) x 1/2" NPTF(m)	1/2"	2,000 psi	8,000 psi
317856-5F	5-1/2'	1/2" NPTF(m) x 1/2" NPTF(f)	1/2"	2,000 psi	8,000 psi
317856-15	15'	1/2" NPTF(m) x 1/2" NPTF(f)	1/2"	2,000 psi	8,000 psi
317856-20	20'	1/2" NPTF(m) x 1/2" NPTF(f)	1/2"	2,000 psi	8,000 psi
317856-25	25'	1/2" NPTF(m) x 1/2" NPTF(f)	1/2"	2,000 psi	8,000 psi
317856-30	30'	1/2" NPTF(m) x 1/2" NPTF(f)	1/2"	2,000 psi	8,000 psi
317856-40	40'	1/2" NPTF(m) x 1/2" NPTF(f)	1/2"	2,000 psi	8,000 psi
317856-50	50'	1/2" NPTF(m) x 1/2" NPTF(f)	1/2"	2,000 psi	8,000 psi
317856-70	70'	1/2" NPTF(m) x 1/2" NPTF(f)	1/2"	2,000 psi	8,000 psi
317856-100	100'	1/2" NPTF(m) x 1/2" NPTF(f)	1/2"	2,000 psi	8,000 psi
339684-15*	15'	1/2" NPTF(m) x 1/2" NPTF(m)	1/2"	2,000 psi	8,000 psi
339684-18*	18'	1/2" NPTF(m) x 1/2" NPTF(m)	1/2"	2,000 psi	8,000 psi

* Swivel male

Low Pressure Air/Water Hoses



Product #	Length	Coupling Spec.	Hose ID	Working psi	Burst psi
317803-3	3'	1/4" NPTF(m) x 1/4" NPTF(m)	3/8"	200 psi	800 psi
317803-7	7'	1/4" NPTF(m) x 1/4" NPTF(m)	3/8"	200 psi	800 psi
317803-15	15'	1/4" NPTF(m) x 1/4" NPTF(m)	3/8"	200 psi	800 psi
317803-20	20'	1/4" NPTF(m) x 1/4" NPTF(m)	3/8"	200 psi	800 psi
317803-25	25'	1/4" NPTF(m) x 1/4" NPTF(m)	3/8"	200 psi	800 psi
317803-30	30'	1/4" NPTF(m) x 1/4" NPTF(m)	3/8"	200 psi	800 psi
317803-40	40'	1/4" NPTF(m) x 1/4" NPTF(m)	3/8"	200 psi	800 psi
317803-50	50'	1/4" NPTF(m) x 1/4" NPTF(m)	3/8"	200 psi	800 psi
317807-5F	5-1/2'	3/8" NPTF(m) x 1/4" NPTF(f)	1/2"	200 psi	800 psi
317809-5F	5-1/2'	1/2" NPTF(m) x 1/4" NPTF(f)	1/2"	200 psi	800 psi
317811-2	2'	1/2" NPTF(m) x 1/2" NPTF(m)	1/2"	200 psi	800 psi
317811-5	5'	1/2" NPTF(m) x 1/2" NPTF(m)	1/2"	200 psi	800 psi
317811-7	7'	1/2" NPTF(m) x 1/2" NPTF(m)	1/2"	200 psi	800 psi
317811-15	15'	1/2" NPTF(m) x 1/2" NPTF(m)	1/2"	200 psi	800 psi
317811-30	30'	1/2" NPTF(m) x 1/2" NPTF(m)	1/2"	200 psi	800 psi
317811-50	50'	1/2" NPTF(m) x 1/2" NPTF(m)	1/2"	200 psi	800 psi
317811-80	80'	1/2" NPTF(m) x 1/2" NPTF(m)	1/2"	200 psi	800 psi
317811-100	100'	1/2" NPTF(m) x 1/2" NPTF(m)	1/2"	200 psi	800 psi

Twin Hoses

Product #	Length	Coupling Spec.	Hose ID	Working psi
340326-30	30'	3/8" NPT(f)	3/8" Twin	9,000 psi
340326-80	80'	3/8" NPT(f)	3/8" Twin	9,000 psi
340328-80	80'	1/2" NPT(m)	1/2"	2,000 psi

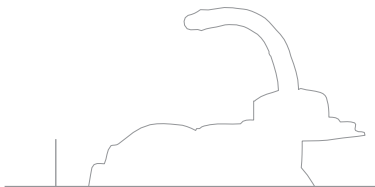
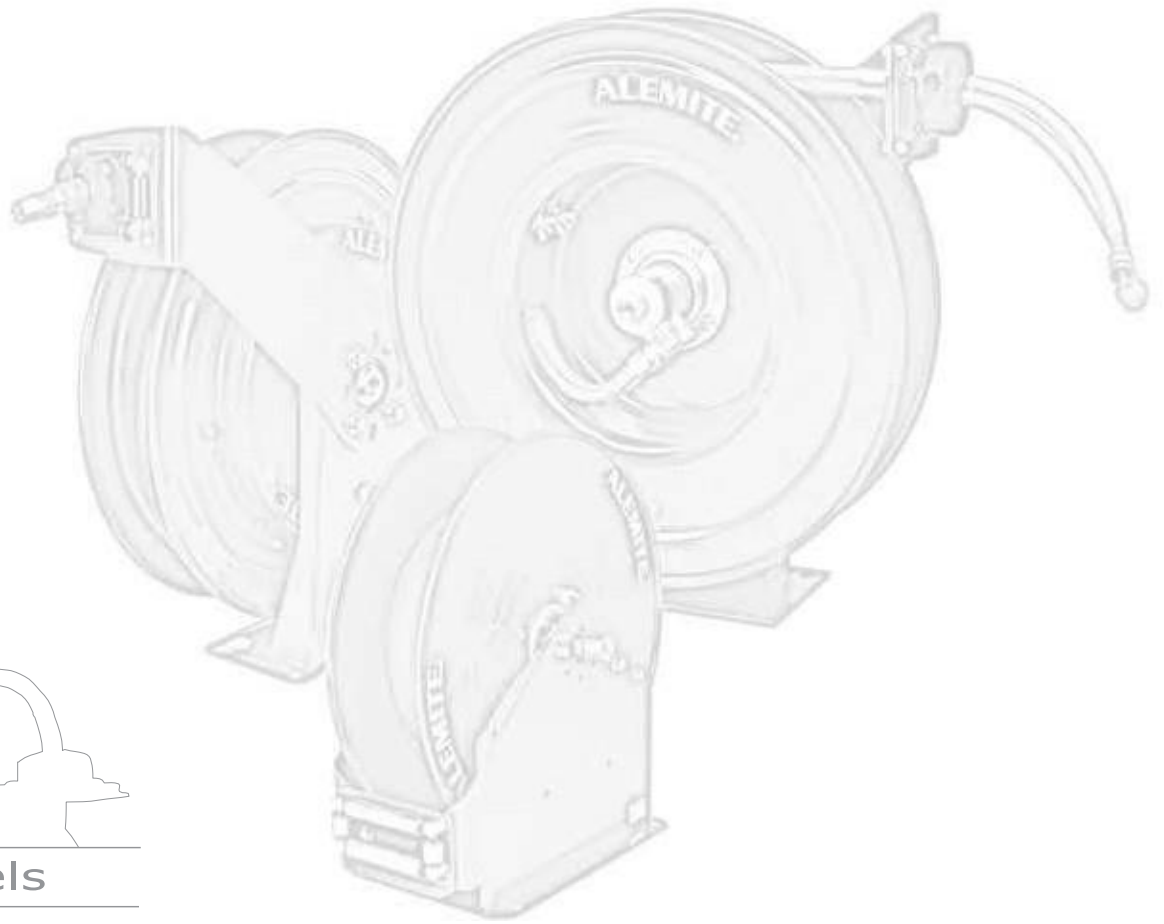

Hose Reels



ALEMITE®

167 Rowland Drive
Johnson City, TN 37601
Toll Free U.S.: 866-4-Alemite
Toll Free Canada: 800-267-8022
International: 803-802-0001
Fax U.S.: 800-648-3917
Fax Canada: 800-267-2880
Fax International: 803-802-0192
www.alemite.com

LIT101 1/07 REV



MFP
AUTOMATION
ENGINEERING