

Mobile On-Road Training

10 Possible Lube Points

Kingpin (both upper and lower), Tie Rod End, Spring Pin, Shackle Pins(2), Transmission Cross Shaft(2), Slack Adjuster, Brake Cam Shaft

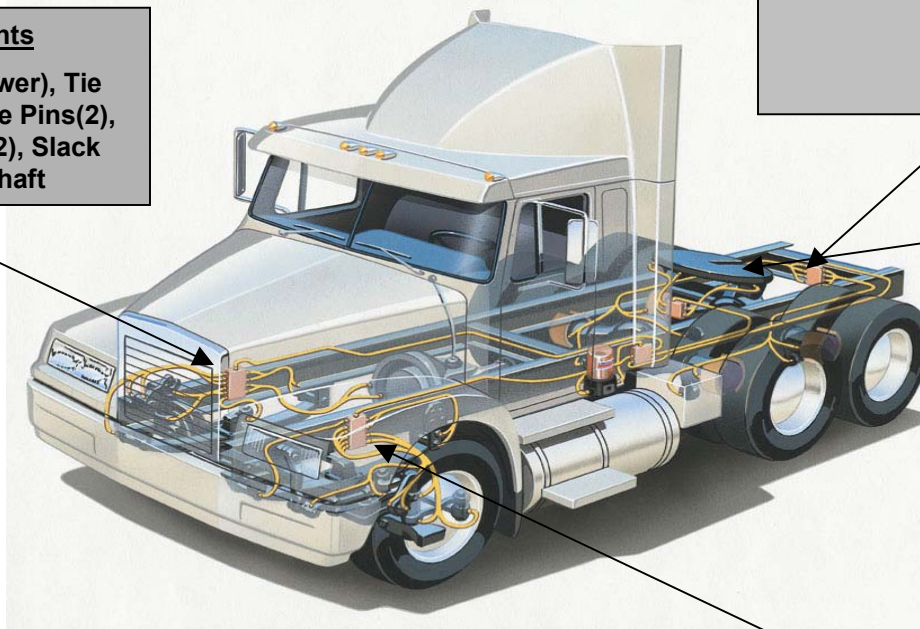

8 Possible Lube Points

Slack Adjusters (1per Wheel), Brake Cam Shafts (1 Per Wheel)

6 Possible Lube Points

Fifth Wheel Faceplate, Fifth Wheel Pivot Pins

10 Possible Lube Points

Kingpin (both upper and lower), Tie Rod End, Spring Pin, Shackle Pins(2), Steering Drag Links(2), Slack Adjuster, Brake Cam Shaft